

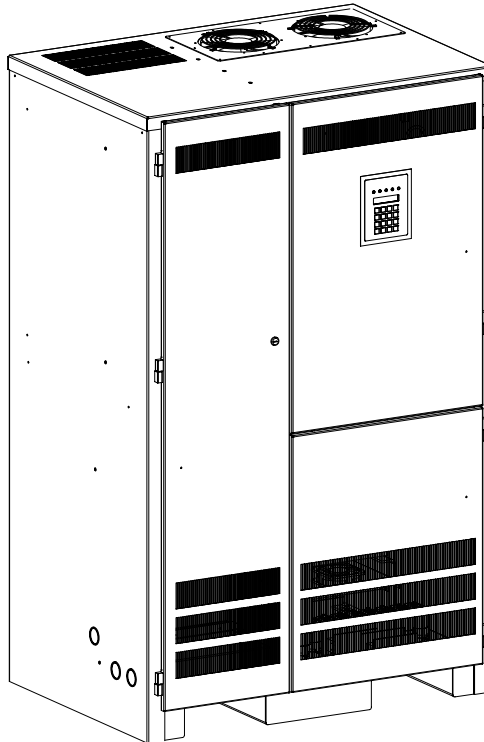

# Illuminator™ System Series CIII

24 kW – 50 kW

## Installation Guide



---

Corporate Headquarters • 2000 Highland Ave, Bethlehem, PA 18020  
1-800-526-5088 • (610) 868-3500 • Fax: (610) 868-8686  
Service: (610) 868-5400

[www.myerspowerproducts.com](http://www.myerspowerproducts.com)

---

This unit contains LETHAL VOLTAGES. All repairs and service should be performed by AUTHORIZED SERVICE PERSONNEL ONLY! There is NO USER SERVICEABLE PARTS inside this unit.

## **IMPORTANT SAFEGUARDS**

When using electrical equipment, you should always follow basic safety precautions, including the following:

- 1. READ AND FOLLOW ALL SAFETY INSTRUCTIONS.**
- 2. Do not install the system outdoors.**
- 3. Do not install near gas or electric heaters or in other high-temperature locations.**
- 4. Use caution when servicing batteries. Depending on battery type, batteries contain either acid or alkali and can cause burns to skin and eyes. If battery fluid is spilled on skin or in the eyes, flush with fresh water and contact a physician immediately.**
- 5. Equipment should be mounted in locations where unauthorized personnel will not readily subject it to tampering.**
- 6. The use of accessory equipment not recommended by Manufacturer may cause an unsafe condition and void the warranty.**
- 7. Do not use this equipment for other than its intended use.**
- 8. Qualified service personnel must perform all servicing of this equipment.**

## **SAVE THESE INSTRUCTIONS**

The installation and use of this product must comply with all national, federal, state, municipal, or local codes that apply. If you need help, please call Service.

**CAUTION**

**READ ENTIRE MANUAL AND REVIEW ALL DOCUMENTATION BEFORE  
ATTEMPTING SYSTEM INSTALLATION!**

FOR SERVICE OR INSTALLATION INFORMATION:  
TELEPHONE: (610) 868-5400 (24 HR. HOTLINE)  
FAX: (610) 954-8227

**FOR YOUR PROTECTION....  
PLEASE COMPLETE AND RETURN WARRANTY REGISTRATION CARD  
IMMEDIATELY.**

## SAFETY WARNINGS

Read the following precautions before you install the UPS.

### IMPORTANT SAFETY INSTRUCTIONS

SAVE THESE INSTRUCTIONS. This manual contains important instructions that you should follow during installation and maintenance of the system and batteries. Please read all instructions before operating the equipment and save this manual for future reference.

---

### DANGER

This system contains **LETHAL VOLTAGES**. AUTHORIZED SERVICE PERSONNEL should perform all repairs and service **ONLY**. There is **NO USER SERVICEABLE PARTS** inside the UPS.

---

### WARNING

- Do not install the system outdoors.
  - Do not install near gas or electric heaters or in other high-temperature locations.
  - Use caution when servicing batteries. Battery acid can cause burns to skin and eyes. If acid is spilled on skin or in the eyes, flush with fresh water and contact a physician immediately.
  - Equipment should be mounted in locations where it is not readily subjected to tampering by unauthorized personnel.
  - The use of accessory equipment not recommended by the manufacturer may cause an unsafe condition.
  - Do not use this equipment for other than intended use.
  - Only qualified service personnel (such as a licensed electrician) should perform the system and battery installation and initial startup. Risk of electrical shock.
-

# CHAPTER 2

## INTRODUCTION

Please read this manual thoroughly before operating your safety system. Keep this manual and the system User's Guide in the folder mounted inside the unit's door.

### **WARNING**

Only qualified service personnel (such as a licensed electrician) should perform the system and battery installation and initial startup. Risk of electrical shock exists.

---

Please record your unit's model number, serial number, and part number below. You can find these numbers on the labels on the inside of the system's right door.

Model Number \_\_\_\_\_

Serial Number \_\_\_\_\_

Part Number \_\_\_\_\_

## CHAPTER 3

# BEFORE INSTALLING THE UNIT

### Installation Dimensions and Clearances

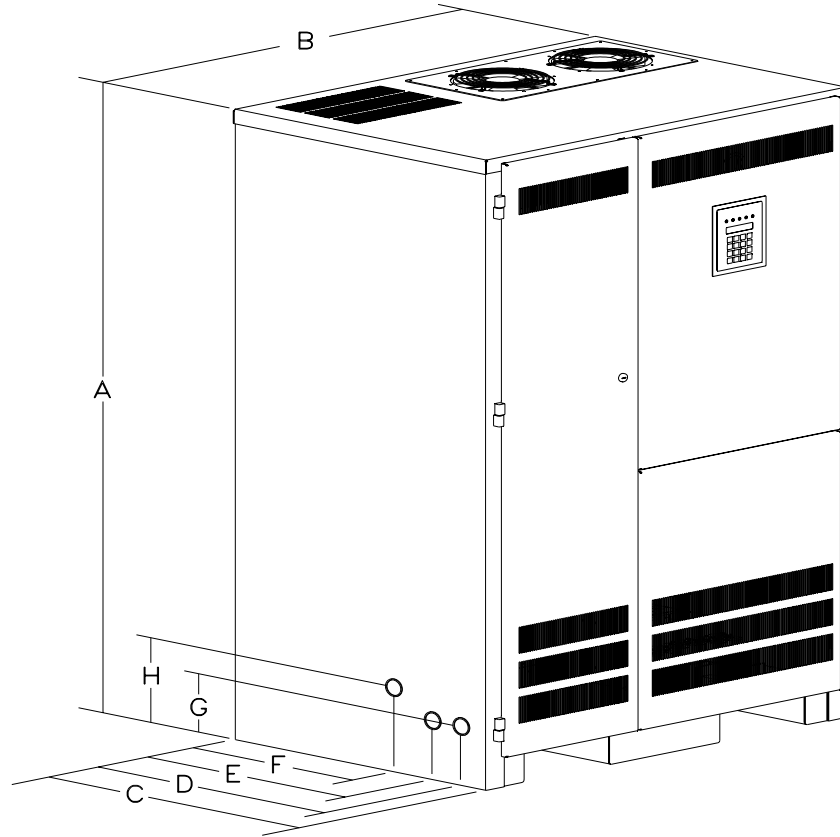

**Figure 3.0 System Dimensions**

**Table 3.1 Dimensions**

Unit	Height (A)	Width (B)	Depth (C)	(D)	(E)	(F)	(G)	(H)
Unit and Battery Cabinets	72" (183 cm)	44" (112 cm)	31" (79 cm)	27.75" (70.48 cm)	24.25" (62.6 cm)	19.5" (49.53 cm)	6.75" (17.15 cm)	9.5" (24.13 cm)

**Table 3.2 Required Clearances**

Sides	Top	Front
0" (0.0 cm)	12" (30.5 cm)	39" (100.0 cm)

**Table 3.3 Conduit Knockouts**

All
2" (5.09 cm)

## Location Guidelines

Keep the following guidelines in mind when choosing the location for your system and batteries:

- Verify that the environment meets the requirements in “Storage and Operating Environment” on page 7. The environment can affect the reliability and performance of both the unit and the batteries.
- Install any separate battery cabinets as close as possible to the unit to reduce the cost of DC wiring and to improve battery performance. We recommend no clearance between the unit and the battery cabinet; in other words, the battery cabinet should be next to (against) the right side of the unit (when you face the front of the unit). If you must place the battery cabinet away from the unit, you must supply the proper length, gauge, and type of battery cables, and you must make sure the installation meets the applicable NEC (CEC) requirements.
- Choose a permanent location for the unit and any battery cabinets. Attempting to move them after you have installed the batteries can damage the batteries and the cabinet.

### CAUTION

Do not move the unit or the battery cabinet after you install the batteries. If you do, the unit or battery cabinet and batteries may be damaged.

CEC requires the unit to be located in a service room. If the room is equipped with a sprinkler system, the unit must be provided with sprinkler proof covers.

This equipment is heavy. Refer to Table 3.4 when you choose a site to make sure that the floor can support the weight of the system, the batteries, any separate battery cabinets, and any other necessary equipment.

**Table 3.4 90 Minute Run Time System Weight [in lbs. (kg)]**

	System Models			
	24kw	33kw	40kw	50kw
Inverter	665 (302)	775 (352)	855 (389)	975 (443)
Battery Cabinet(s) with Standard SLC Batteries	5500 (2500)	7000 (3182)	9000 (4091)	10500 (4773)
Battery Cabinet(s) without Batteries	1000 (455)	1000 (455)	1500 (682)	1500 (682)

## Receiving and Moving the Unit and the Batteries

Systems weigh several hundred pounds; separate battery cabinets are also heavy (see Table 3.4; ask your sales representative for additional information). Make sure you are prepared for these weights before you unload or move the unit or the batteries. Do not install any batteries until you have permanently installed the unit and any battery cabinets and connected all conduit and wiring.

## Storage and Operating Environment

Make sure you store and install the system in a clean, cool, dry place with normal ventilation for human habitation and level floors.

### Storage Temperature

Store the batteries (in the system or battery cabinet) at -18 to 40°C (0 to 104°F). Batteries have a longer shelf life if they are stored below 25°C (77°F). Keep stored batteries fully charged. Recharge the batteries every 90–120 days. The system or battery cabinet without batteries may be stored at -20 to 70°C (-4 to 158°F).

### Ventilation

The air around the unit must be clean, dust-free, and free of corrosive chemicals or other contaminants. Do not place the system or batteries in a sealed room or container.

### Operating Temperature

System can operate from 20° to 30°C (68° to 86°F) and up to 95% relative humidity. The batteries' service life is longer if the operating temperature stays below 25°C (77°F).

### Batteries

The temperature should be near 25°C (77°F) for optimum battery performance. Batteries are less efficient at temperatures below 18°C (65°F), and high temperatures reduce battery life. Typically, at about 35°C (95°F), battery life is half of what it would be at a normal temperature of 25°C (77°F). At about 45°C (113°F), battery life is one-fourth of normal.

Make sure that heaters, sunlight, air conditioners, or outside air vents are not directed toward the batteries. These conditions can make the temperature within battery strings vary, which can cause differences in the batteries' voltages. Eventually, these conditions affect battery performance.

If the batteries are not in the system, remember that the batteries should be installed as close as possible to the unit to reduce DC wiring costs and improve battery performance.

Do not allow tobacco smoking, sparks, or flames in the system location because hydrogen is concentrated under the vent cap of each cell of the battery. Hydrogen is highly explosive, and it is hard to detect because it is colorless, odorless, and lighter than air.

Every type of battery can produce hydrogen gas, even sealed maintenance-free batteries. The gas is vented through the vent caps and into the air, mainly when the unit is charging the batteries. The batteries produce the most hydrogen when maximum voltage is present in fully charged batteries; the batteries do not produce hydrogen during float charging. The amount of current that the charger supplies to the batteries (not the battery ampere-hour) determines how much hydrogen is produced.

### High Altitude Operation

The maximum operating ambient temperature drops 1°C per 300m (2°F per 1000 ft) above sea level. Maximum elevation is 3000m (10,000 ft).

# CHAPTER 4

## INSTALLATION OVERVIEW

Figure 4.0 shows typical installations of system

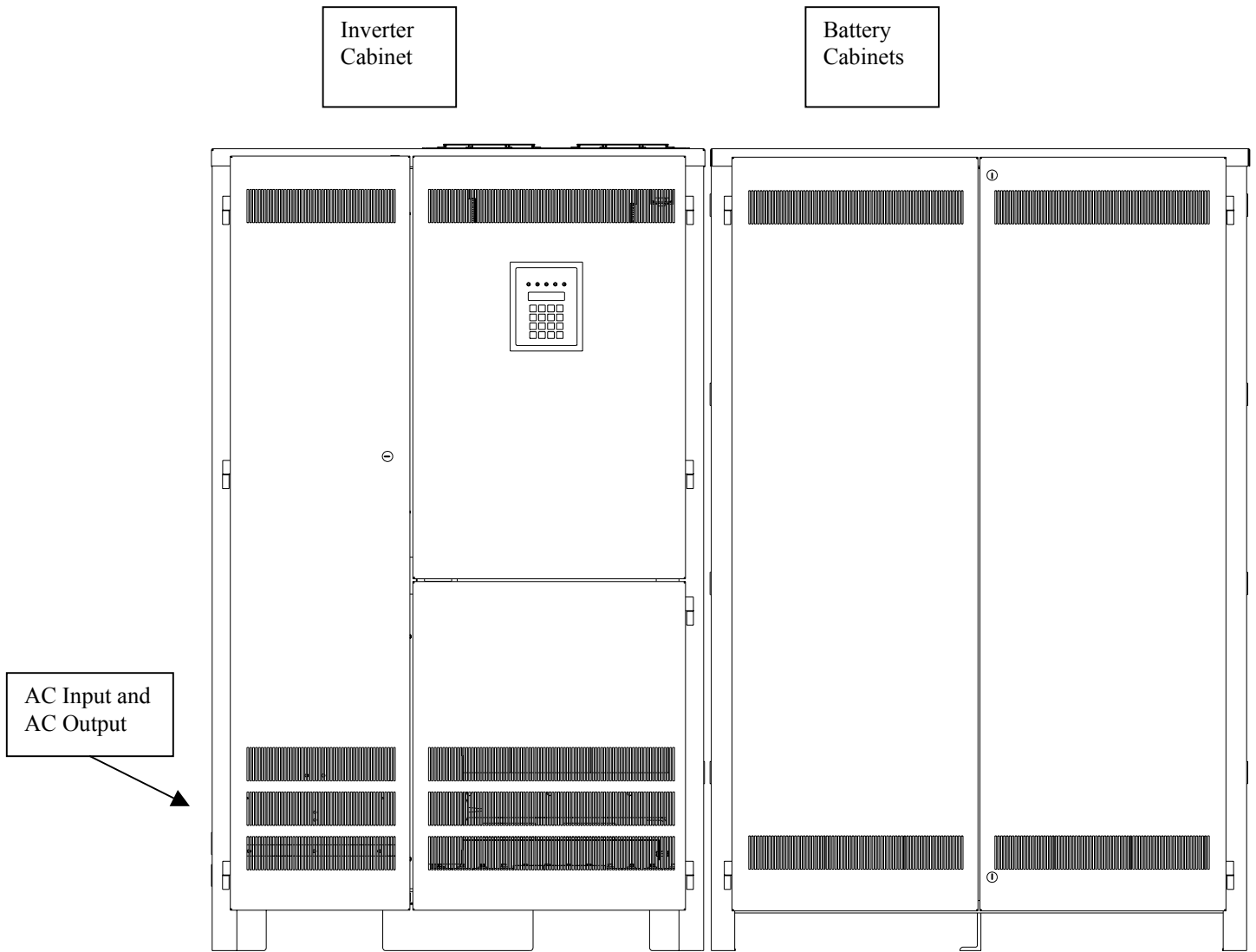

Figure 4.0 Typical Hardwired Installation

## CHAPTER 5

# AC INPUT & AC OUTPUT INSTALLATION

### WARNING

Only qualified service personnel (such as a licensed electrician) should perform the AC installation. Risk of electrical shock exists.

---

Read the following cautions before you continue.

### CAUTION

- Unit contains hazardous AC and DC voltages. Because of these voltages, a qualified electrician must install the system, AC line service, and batteries. The electrician must install the AC line service according to local and national codes and must be familiar with batteries and battery installation.
  - Before you install, maintain, or service the unit, always remove or shut off all sources of AC and DC power and shut off the system. You must disconnect AC line input at the service panel and turn off the Installation Switch (S1), the Main AC Input Circuit Breaker (CB1), and the Battery Fuse(s) to make sure the unit does not supply output voltage.
  - Whenever AC and/or DC voltage is applied, there is AC voltage inside the unit; this is because the unit can supply power from AC line or from its batteries. To avoid equipment damage or personal injury, always assume that there may be voltage inside the unit.
  - Remove rings, watches, and other jewelry before installing the AC wiring. Always wear protective clothing and eye protection and use insulated tools when working near batteries. Whenever you are servicing an energized unit with the inside panel open, electric shock is possible; follow all local safety codes. **TEST BEFORE TOUCHING!**
  - To reduce the risk of fire or electric shock, install the unit and its batteries in a temperature- and humidity-controlled indoor area free of conductive contaminants. See page 8 for operating environment specifications.
- 

1. Open the unit's doors. Make sure the installation switch and the input circuit breaker are off, and the battery fuse removed inside the unit.
2. Look at the ID label on the inside right door. Write down the following information:  
Input Voltage: \_\_\_\_\_  
Output Voltage: \_\_\_\_\_
3. Now, make sure the input and output voltages are what you need

**The Input must be a 4 wire three phase – Neutral must be connected.**

Does the input voltage available for the system at the AC service panel match the input voltage shown on the unit's ID label?

Service Panel Voltage = \_\_\_\_\_ Input Voltage \_\_ Yes / \_\_ No

- Does the output voltage on the ID label match the voltage your loads (protected equipment) need?

Load Voltage = \_\_\_\_\_ Output Voltage \_\_ Yes/ \_\_ No

If you answered NO to either of the preceding questions, **call SERVICE.**

4. Now, use the information you wrote down in Step 2 to find the correct circuit breaker for the service panel that is for your system.

**Table 5.1 Recommended Circuit Breaker for Maximum Input Current**

System	Input Voltage (Vac)	Max. Current	Recommended Circuit Breaker
24 KW	120 / 208	84	100
24 KW	277 / 480	36	45
33 KW	120 / 208	115	150
33 KW	277 / 480	50	60
40 KW	120 / 208	139	175
40 KW	277 / 480	60	80
50 KW	120 / 208	174	225
50 KW	277 / 480	75	90

**\*\* WARNING: THE EXTERNAL INPUT CIRCUIT BREAKER PROTECTING THE SYSTEM MUST BE A “MOTOR START”, DELAYED TRIP TYPE. THIS IS DUE TO MAGNETIC INRUSH CURRENT DRAWN DURING APPLICATION OF AC POWER. PLEASE NOTE THAT THIS APPLIES TO ANY UNIT THAT HAS A DIFFERENCE BETWEEN THE INPUT AND THE OUTPUT VOLTAGES.**

5. Write down the circuit breaker value that applies to your system from Table 5.1:
6. Now, look at Table 5.2 below, and use the notes below to find the proper gauge wire or the recommended circuit breaker recorded in step 5.

**Table 5.2 Recommended Minimum Wire Sizes**

Read These Important Notes!	For this Input Circuit Breaker Size...	Use this Size 90°C Copper Wire	
		AWG	mm <sup>2</sup>
This table lists the AWG and mm2 wire size for each circuit breaker size. The minimum recommended circuit breaker sizes for each model and voltage application are listed in Table 5.1. The temperature rating of conductor must not be less than 90° C wire. Based on the ampacities given in Tables 310-16 of the National Electrical Code, ANSI/NFPA 70-1993 (Table 2 of the CEC), and NEC article 220 (CEC Section 4). All circuit conductors, including the neutral and equipment-grounding conductors, must be the same size (ampacity) wires. Code may require a larger wire size than shown in this table because of temperature, number of conductors in the conduit, or long service runs. Follow local code requirements.	10, 15, 20	12	3.31
	25, 30	10	5.26
	35, 40, 45	8	8.36
	50, 60	6	13.30
	70, 80	4	21.15
	90, 100	2	33.62
	110	1	42.11
	125	1/0	53.49
	150, 175	3/0	67.43
	225	4/0	74.40

7. The input circuit breaker in the input service panel provides the means for disconnecting AC to the unit. Only authorized persons shall be able to disconnect AC to the unit [see NEC 700-20 and 700-21(CEC Section 46)]. If you are using the input circuit breaker to disconnect AC, you must make sure that only authorized persons have control of the circuit breaker panel to meet the requirements of NEC 700-20 (CEC Section 46).
8. Read the following caution before removing conduit knockouts.

### CAUTION

To prevent electrical shock or damage to your equipment, the Installation Switch (S1), the Main AC Input Circuit Breaker (CB1), and the circuit breaker at the input service panel should all be turned off. The Main DC Battery Fuse and the external DC Disconnect Fuse(s) (if you have one) should be removed.

---

9. Remove knockouts for AC Input and AC Output in the top or left side of the system. AC input conductors and AC output conductors must be installed in separate conduits, and emergency and non-emergency output circuits must be installed in separate conduits.

### CAUTION

Do not drill the cabinet; drill filings may damage the unit and keep it from operating. If you need larger knockouts, use a chassis punch to punch out the appropriate knockout. Do not create additional knockouts.

10. Install the conduit. You must run the AC input service conductors and AC output conductors through separate conduits. Emergency output conductors and non-emergency output conductors must also be run through separate conduits. Emergency output circuits shall be installed in dedicated conduit systems and not shared with other electrical circuits as described in NEC 700-9(b) [CEC Section 47-108].

The next step explains where to make the AC connections to the system.

#### **INSTALLING AC INPUT WIRES:**

11. Connect AC utility from the service panel to the system's terminal block labeled "**INPUT**".

**Phasing must be clockwise Rotation** – i.e. Phase B lags Phase A.

Connect each Line (hot) wire to each of the input block positions marked "**Line**", connect the Neutral (common) wire to the input block marked "**Neutral**" and the ground wire to the compression lug next to the input terminal block.

#### **INSTALLING AC OUTPUT WIRES:**

**\*\*IF EXTERNAL MAINTENANCE BYPASS IS REQUIRED, SEE DEVIATION DRAWING FOR WIRING OF LOAD OUTPUT.**

12. Connecting load wires without system distribution circuit breakers – connect load wires to the system's terminal block labeled "**OUTPUT**". Repeat as in step 11.
13. Connecting load wires with distribution circuit breakers – connect load wires directly to the circuit breakers and the neutral wires to the neutral bar.

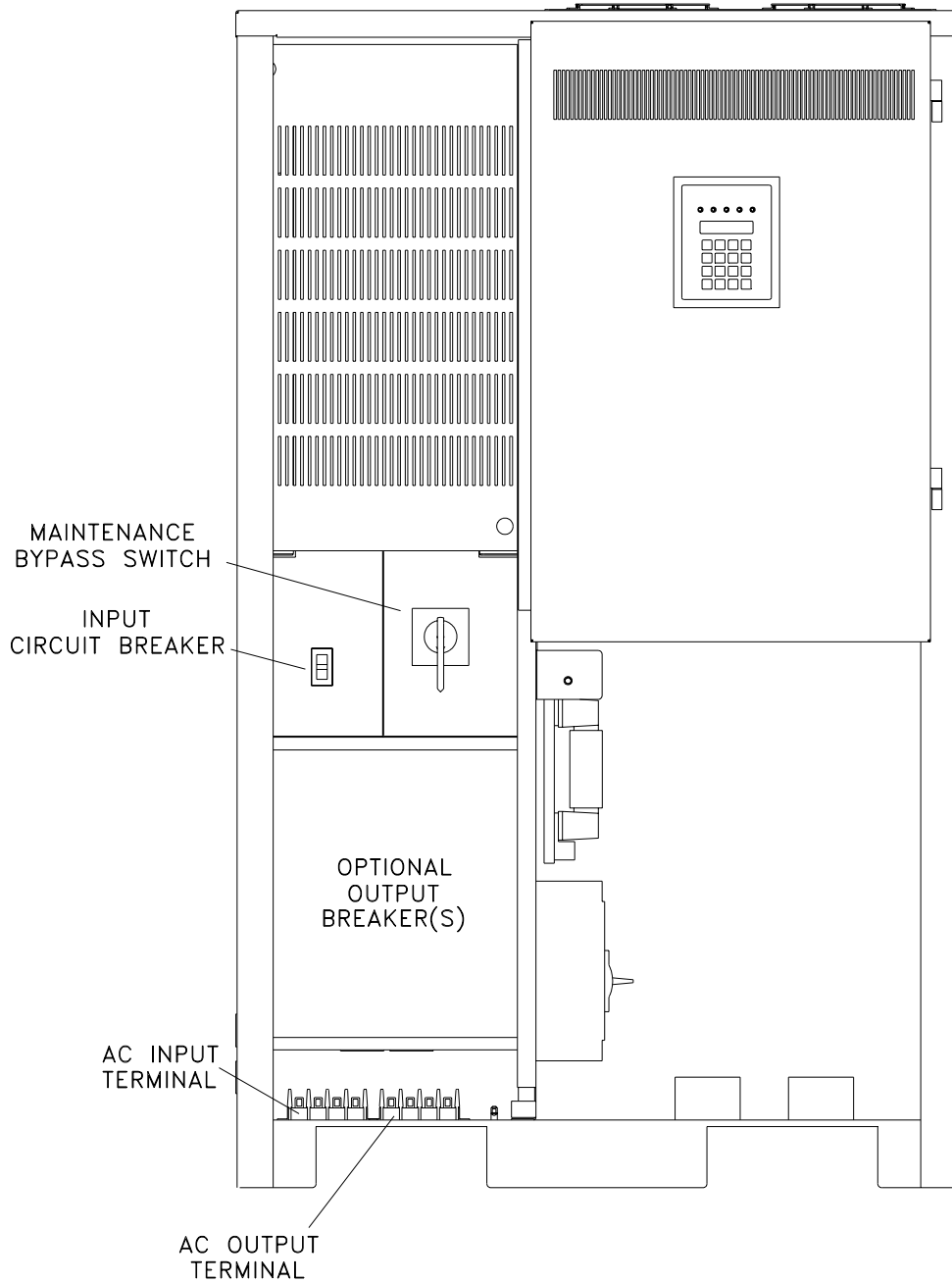

**Figure 5.0 AC Input and Output Locations**

## CHAPTER 6

# INSTALLING BATTERIES AND DC WIRING

### WARNING

Only qualified service personnel (such as a licensed electrician) should perform the battery and DC wiring installation. Risk of electrical shock exists.

---

This section explains how to install system batteries, fuses, and cables. An electrician who is familiar with battery installations and applicable building and electrical codes should install the batteries.

### WARNING

The batteries that will need to be installed in this system could cause you harm or severely damage the electronics if proper precautions are not followed. Batteries connected in series parallel configuration could produce lethal voltages with unlimited current. All batteries should be inspected for damage prior to installation. Never install a battery that is leaking electrolyte. Battery terminals should be cleaned with a wire brush to remove any oxidation. All tools should be insulated. Rubber gloves and safety glasses are recommended. **IN THIS SYSTEM BATTERY NEGATIVE IS TIED TO GROUND INSIDE THE INVERTER.** This means that the battery cabinet and shelves are at ground potential as soon as negative connections are made to the batteries. It is strongly recommended to make all negative connections to the batteries the last step to prevent any chance of shorting battery positive to ground. With the DC fuse removed, make connections to battery positive first, working your way towards battery negative. Leave individual strings of batteries open at the last battery negative until all batteries are installed. Then connect each strings negative.

## Safety Instructions

### IMPORTANT SAFETY INSTRUCTIONS

#### SAVE THESE INSTRUCTIONS

This section contains important instructions that a qualified service person should follow during installation and maintenance of the system and batteries. **ONLY** a qualified service person should work with the batteries.

---

### CAUTION

Full voltage and current are always present at the battery terminals. The batteries used in this system can produce dangerous voltages, extremely high currents, and a risk of electric shock. They may cause severe injury if the terminals are shorted together or to ground (earth). You must be extremely careful to avoid electric shock and burns caused by contacting battery terminals or shorting terminals during battery installation. Do not touch uninsulated battery terminals.

A qualified electrician familiar with battery systems and required precautions must install and service the batteries. Any battery used with this unit shall comply with the applicable requirements for batteries in the standard for emergency lighting and power equipment, UL 924 (Canada's National Building Code). Cabinets are designed to be used with, and batteries must be replaced with, manufacturer battery number BAT-CG12042 or a manufacturer approved equivalent (see the battery wiring diagram that came with the battery cables). If you substitute batteries not supplied by manufacturer, the unit's UL (cUL) listing is void and the equipment may fail. Installation must conform to national and local codes as well. Keep unauthorized personnel away from batteries. The electrician must take these precautions:

Wear protective clothing and eyewear. For battery systems >48vdc, wear rubber gloves and boots. Batteries contain corrosive acids or caustic alkalis and toxic materials and can rupture or leak if mistreated. Remove rings and metal wristwatches or other metal objects and jewelry. Don't carry metal objects in your pockets where the objects can fall onto the batteries or into the system or battery cabinet.

Tools must have insulated handles and must be insulated so that they do not short battery terminals. Do not allow a tool to short a battery terminal to another battery terminal or to the cabinet at any time. Do not lay tools or metal parts on top of the batteries, and do not lay them where they could fall onto the batteries or into the cabinet.

Install the batteries as shown on the battery-wiring diagram provided with the system. When connecting cables, never allow a cable to short across a battery's terminals, the string of batteries, or to the cabinet.

Align the cables on the battery terminals so that the cable lug does not contact any part of the cabinet even if the battery is moved. Keep the cable away from any sharp metal edges.

---

### **CAUTION**

Install the battery cables so they cannot be pinched by the battery cabinet or the system doors.

External battery cabinet chassis ground (or earth) must be connected to the system's chassis ground (or earth). The ground conductor must be insulated. If you use conduit, this ground conductor must be routed in the same conduit as the battery conductors.

Where conductors may be exposed to physical damage, protect conductors in accordance with the National Electrical Code (NEC) [Canadian Electrical Code (CEC)].

If you are replacing batteries or repairing battery connections, follow the procedure in the system user's Guide to shut down your system and remove both AC and DC input power.

---

## Before Installing the Batteries

### Tools

#### CAUTION

Always use insulated tools when you work with batteries. Always torque connections to the manufacturer's recommendations.

When you work with system batteries, you need the following tools. The tools must be insulated so they do not short battery terminals to the cabinet. Wear the safety equipment required by local code whenever the doors are open and whenever you are working on batteries. Other tools may be necessary for optional batteries.

- Digital volt-ohm meter
- 7/16" open end wrench
- 3" extension socket
- Ratchet
- Wire brush
- Electrical tape
- Conductive grease or petroleum jelly
- Brush (to apply grease or petroleum jelly to terminals)
- Safety equipment required by local codes
- Torque wrench calibrated in inch-pounds or Newton-meters
- 7/16" socket wrench
- Safety glasses with side shields

### Battery Voltage (vdc)

Models	24k	33k	40k	50.0k
Battery	240v	240v	240v	240v
Volts				

### Battery Cable Sizing

The battery cable or wire used varies. For the 100 AH battery (SL-12105) the size is 6 AWG. For the 200 AH battery (SL-12205), the size is 4 AWG. This is because the batteries string current varies with battery type.

If the batteries must be more than two feet (0.6 meters) from the system, you may need to install larger battery cables between the battery cabinets and the system. Using long cable runs and larger diameter cables require a modified installation of the system; call SERVICE if you did not order the longer, larger-diameter cable with the system.

### DC Disconnect

Systems have a Main Battery Circuit Breaker inside the electronics cabinet; this breaker lets you remove DC power from the batteries. Systems also have a fuse on each battery string located in the battery cabinets.

# Installing and Connecting the Batteries

## Battery Wiring Diagram

You should have received a battery-wiring diagram with your system. This battery-wiring diagram shows how you should install the batteries, make terminal, and fuse connections. Use the diagram as you follow the steps below.

## Location

Before you start installing the batteries, you must install the system and any battery cabinets in their permanent location. If you have not already done this, see “Location Guidelines” on page 7 to choose a location.

### CAUTION

To prevent damage to your equipment, do not move the system or separate battery cabinets after the batteries are installed.

To make sure a location is acceptable for the system, review the requirements in Chapter 3.

## Connecting the Cabinets

Wherever conductors may be exposed to physical damage, you must protect the conductors in accordance with the NEC (CEC). This includes battery cables between the system and a separate battery cabinet and cables between battery cabinets (if you have more than one).

We recommend routing the battery cable through the chase nipples. The battery cables shipped with the unit are designed for an installation with the battery cabinet immediately to the right of (touching) the system.

If the cabinets must be farther apart, we recommend that you use conduit (cables not included). Install the conduit for the battery cables according to local or national codes. If you are using conduit, you must substitute your own cables for the cables shipped with the unit as you follow the battery installation instructions. Remember that the terminal blocks supplied with the unit and battery cabinets accept up to 4/0 AWG (21.15 mm<sup>2</sup>) wire. If code requires a larger size cable, you must use cable splices. Perform the splices when the instructions describe terminations at the terminal blocks. Use the correct type, length, and gauge of cable; make sure your installation meets all applicable electrical codes.

## Installing the Battery Cables between Cabinets

You must pull the battery cables and the equipment-grounding conductor through the connecting nipple or through the conduit between the unit and the battery cabinet(s).

**NOTE** *If you are using conduit, you must supply the correct length, gauge, and type of battery cables.*

Refer to the battery-wiring diagram to identify the battery cables you use to connect the unit to the battery cabinet(s). Pull the cables through the nipple or conduit. Do not connect any cables at this time.

If your unit has more than one battery cabinet, use the battery-wiring diagram to identify the cables you use to connect the battery cabinets. Pull these cables through the connecting nipple or conduit. Do not connect the cables.

## Making the Equipment Ground Connection

Each battery cabinet ground (or earth) must be connected to the system's chassis ground. You can make this connection at the ground terminals inside the system and the battery cabinet as follows.

### CAUTION

All grounding conductors should be insulated. If you are using non-insulated grounding conductors, take special care to make sure that the grounding conductors cannot accidentally contact live wires or the batteries.

In the system, find the ground compression lug labeled "**GROUND**". This terminal is next to the AC terminal blocks.

1. You must supply the equipment-grounding conductor that connects the system to the nearest (or only) battery cabinet. Strip 0.5" (1.3 cm) of insulation from each end of the equipment-grounding conductor. Then, connect one end of the conductor to the ground lug in the system.
2. At the battery cabinet's ground lug. Connect the end of the grounding conductor to this lug.
3. If the unit has two battery cabinets, you must supply the grounding conductor that connects the cabinets. Strip 0.5" (1.3 cm) of insulation from each end of this grounding conductor. Connect one end to the ground lug in the first battery cabinet, and connect the other end to the matching ground lug in the next battery cabinet. Repeat this step if you have more than two battery cabinets.

**NOTE** When you connect a separate equipment grounding conductor directly to building steel, use the knockouts that are already on the unit. Do not make a knockout anywhere on the cabinet where there is not already a knockout.

### Electronics Cabinet Battery Block Connections

Do not connect any battery cables at this time. In the following procedure, you should only make connections to the electronics cabinet's battery block. Use the battery-wiring diagram shipped with the battery cables as you follow these steps.

1. Find the positive battery cable pulled between the electronics cabinet and the battery cabinet. At the ends of the cable, strip off 0.5" (1.3 cm) of insulation. Now, look at the battery-wiring diagram. Notice that this cable is connected from the positive position of the battery terminal block inside the electronics cabinet to the outside of the fuse block inside of the battery cabinet. Insert the positive (+) cable into fuse block and into the terminal block. Torque the connections as shown on the battery-wiring diagram.
2. Find the negative battery cable pulled between the electronics cabinet and the battery cabinet. At the bare end of the cable, strip off 0.5" (1.3 cm) of insulation. Now, look at the battery-wiring diagram. Notice that this is connected from the negative position of the battery terminal block inside the electronics cabinet to a battery inside of the battery cabinet. Insert the negative (-) cable into the terminal block and insulate the other end that is in the battery cabinet. Torque the connection as shown on the battery-wiring diagram.
3. Repeat step 1 and 2 for units with 2 strings (10 kW, 12.5 kW, and 16.7 kW systems).

## Interconnect Connections between Battery Cabinets

Systems that split a battery string between 2 battery cabinets (8 kW and 16.7 kW systems):

Find the battery cable that connects to the fuse block. At the bare end of the cable, strip off 0.5" (1.3 cm) of insulation. Insert the cable into the fuse block. Torque the connection as shown on the battery-wiring diagram.

### Fuse

All systems come with a fuse for each battery cabinet to protect the system. The battery-wiring diagram shows the fuse location; a label inside the battery cabinet shows the fuse size. The system itself has a DC fuse. At each battery cabinet, find the cable that is connected to the other end of the fuse block. Insert the cable. Torque the connection as shown on the battery-wiring diagram.

Repeat this step for each cabinet.

**Verify that the battery fuse in the electronics cabinet is removed and the fuse(s) in the battery cabinet(s) are removed before connecting the batteries.**

## Arranging the Batteries

**NOTE** *As you arrange the batteries, you must be wearing the required safety equipment.*

Arrange the batteries in the cabinet or the system only as shown in the battery-wiring diagram. This arrangement is designed to maximize airflow around the batteries. The cabinets are designed so that battery cases should never touch. Air should be free to circulate. Clean the entire surface of all battery terminals with the wire brush before you install the batteries to create good contact points.

Load the batteries into the system or battery cabinet(s). Starting with the bottom shelf, load one shelf at a time.

### CAUTION

Never install the batteries in an airtight enclosure.

## Connecting the Cables Between Batteries

When you make battery terminal connections, use the torque wrench to tighten the battery terminal connections securely. For most batteries, you can find out what torque value to use by finding the battery number on the top of the battery. Then, use Table 6.1 to find the torque value for that battery.

**Table 6.1 Battery Torque**

Battery Type	Torque
PRC-12100S	Torque to 70 in lbs. (7.9 Nm)
UPS12- 310	Torque to 65 in lbs. (7.4 Nm)
SL-12105	Torque to 120 in lbs. (13.6 Nm)
SL-12205	Torque to 120 in lbs. (13.6 Nm)

Now, follow these steps to connect the cables:

1. Using the battery-wiring diagram, determine which batteries belong to each battery string.
2. Clean the cable connectors with the wire brush before you make the battery connections.

**NOTE** As you carry out the following step, use these guidelines:

*If you are using conductive grease, apply a thin coating of high-temperature conductive grease on each post and every cable connector before you assemble and torque the connection to slow corrosion.*

*If you use nonconductive grease like petroleum jelly, do not apply any grease before you make the connections and torque them. Instead, make the connection first; then, torque it to the value shown in Table 6.1. After you make the connection; apply a coating of the nonconductive grease to the hardware at the battery terminals.*

3. In each battery string, connect the battery cables between the batteries as shown in the battery-wiring diagram (positive terminal to negative terminal). Torque the connections to the value shown for your battery in Table 6.1.
4. Connect the battery cables from one shelf to the next as shown on the battery-wiring diagram.
5. Connect the fuse block to the positive of the battery as shown on the battery-wiring diagram.

### **CAUTION**

Hazardous voltage is present! System batteries are high current sources. These batteries can produce dangerous voltages, extremely high currents, and a risk of electric shock.

6. Install only the battery cabinet(s) fuse(s). Next, use the voltmeter to check the DC voltage between the positive (+) position on the battery block inside the electronics cabinet and the unconnected battery negative terminal. This voltage should be approximately the battery voltage record on the unit ID label. If it is greater than + or – 5%, review the battery wiring diagram. Correct any wiring errors and recheck the DC voltage; do not go on until your measurement is within + or – 5%. If the measurement is too high and you cannot find the cause of the problem, call SERVICE.

## CAUTION

If you do not verify that voltage and current direction are correct, the equipment may fail.

### **Connecting the Negative Battery Cable(s) to the Battery String(s)**

Remove the insulation from the cable that was put on in step 2 of “Electronics cabinet battery block connections”. Connect the cable to the battery (-) negative. Repeat this step for systems with multiple strings.

## **Replacing the Batteries**

### CAUTION

A battery can present a risk of electrical shock and high short circuit current. A qualified electrician familiar with battery systems should service the batteries.

---

Review all the safety instructions at the beginning of this chapter before you replace any batteries.

### **Use the Same Quantity and Type of Battery**

### CAUTION

You must use the same quantity and type of battery. Substituting batteries not supplied by manufacturer voids the UL (CUL) listing and may cause equipment damage.

---

To ensure continued superior performance of your system and to maintain proper charger operation, you must replace the batteries in the system or battery cabinets with the same number of batteries. These batteries must be the same types as the original batteries. The replacement batteries should have the same voltage and ampere-hour rating as the original batteries.

### **Handle Used Batteries with Care!**

Assume that old batteries are fully charged. Use the same precautions you would use when handling a new battery. Do not short battery terminals or the battery string with a cable or tool when you disconnect the batteries! Batteries contain lead. Please dispose of old batteries properly.

### CAUTION

Do not dispose of batteries in a fire because the batteries could explode. Do not open or mutilate batteries. Released electrolyte is harmful to the skin and eyes. It may be toxic.

### **Dispose of Batteries Properly**

### CAUTION

Batteries contain lead. Many state and local governments have regulations about used battery disposal. Please dispose of the batteries properly.

## CHAPTER 7

# SETTING THE AUTOMATIC SYSTEM TEST PARAMETERS

Several parameters in the system software determine when and how your system conducts the automatic monthly and annual tests. Refer to “Program Functions” in the “Front Panel Display” chapter of the system user’s Guide for a description of each test.

### Starting the Unit

Before you can set the parameters, you must start the system.

#### **WARNING**

Verify that the system AC Input Circuit Breaker and Installation Switch are off.

1. Turn on the AC input at the building service panel; ensure that the systems input breaker (CB1) is off.
2. Locate the DC Pre-charge Switch (S2) see figure 7.0; press it for five seconds; then, turn the battery breaker on inside the electronics cabinet.
3. Turn on the System AC input circuit breaker (CB1). (See figure 5.0 )
4. Turn on the Installation Switch (S1). Leave the loads (protected equipment) off. Unit will run on batteries, then transfer to normal mode.

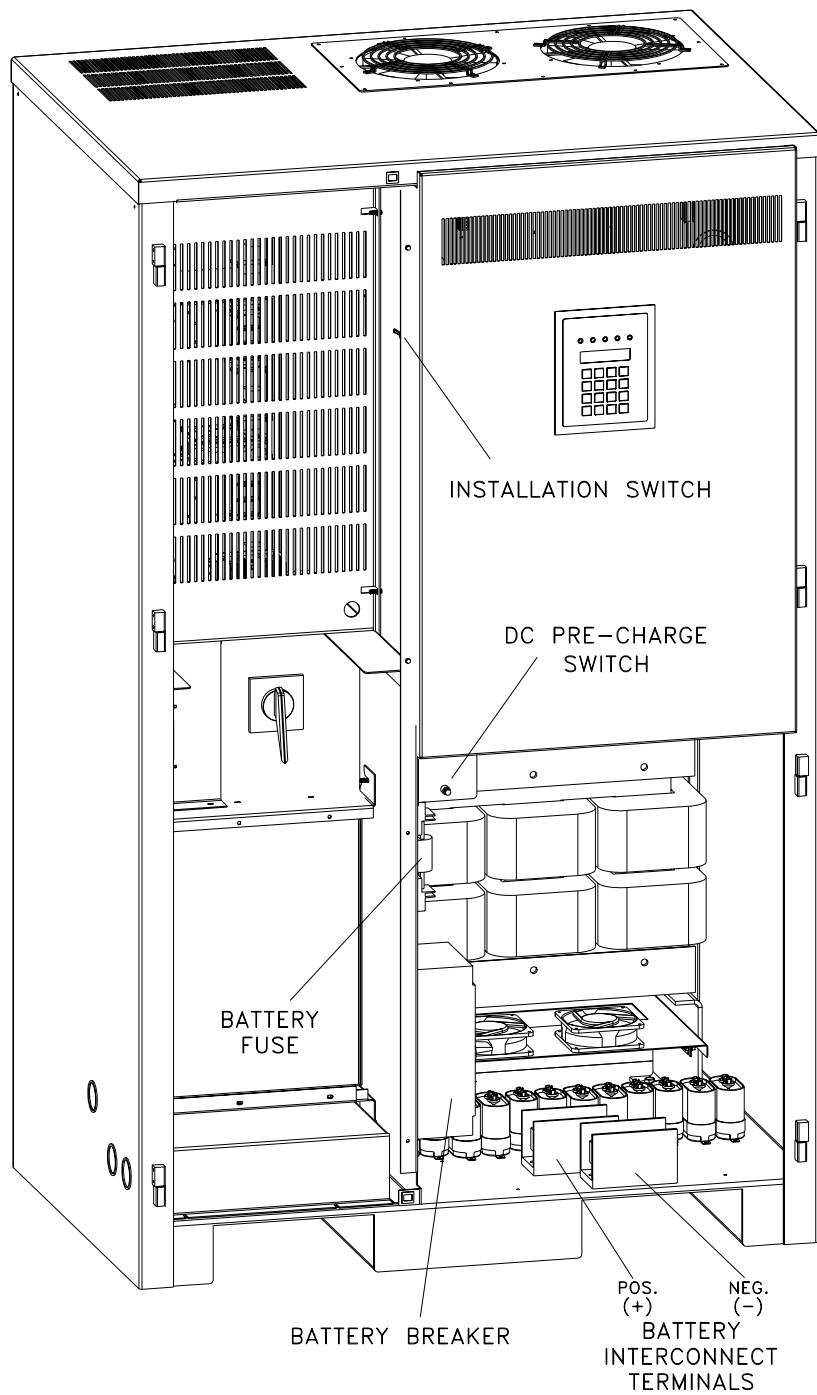

**Figure 7.0 Battery Fuse, DC Pre-charge Switch & Installation Switch**

# Front Panel Display

The Front Panel Display consists of a 2 x 20 alpha numeric LCD display with LED back lighting, 5 status LED indicators and a 4 x 4 keypad for user interface.

## Control Panel Keypads

**Table 7.1 Keypad Functions**

Key Name	Description
Meter (Blue)	Pressing this key will activate Meter Functions
Control (Red)	Pressing this key will activate Control Functions
Program (Black)	Using this key, you can enter passwords or change parameter values. To enter passwords, press [PROGRAM], enter the password, and press [ENTER]. NOTE: A password must be entered to change parameters.
Enter (Grey)	This key records or enters a task you perform using the control panel keys.
[ ◀ ]	This key functions as Left scroll key
[ ▶ ]	This key functions as Right scroll key
[ 0 ]	This key works as a number key; it is also used to display active alarms when in CONTROL Mode.
[ 1 ] through [ 9 ]	These keys work as number keys. ( <b>See User Manual for further specific functions of Keys</b> )

## Meter Functions

Meter functions are available by pressing the **METER** keypad to get to the Meter Menu and then pressing the desired function keypad. (See figure 7.3)

**Table 7.2 Meter Functions**

Function	Description	Keypad Text
Voltage Input	Measures the AC Input Voltage to the Inverter	V IN
Voltage Output	Measures the AC Output Voltage from the Inverter	V OUT
Current Output	Measures the AC Output Current from the Inverter. If optional Normally Off loads is connected, it will read the sum of Normally On and Normally Off outputs.	I OUT
Battery Voltage	Measures Battery Voltage	V BATT
Battery Current	Measures the Battery Current. When in charge mode, the current will be positive. When in Inverter mode, the current will be negative.	I BATT
VA Output	Multiplication of the output voltage and output current	VA OUT
Inverter Watts	Multiplication of the battery voltage and the battery current	INV. WATTS
Inverter Minutes	Total minutes the system has run on inverter	INV. MIN
Temperature	Measures the ambient temperature of the electronics enclosure.	TEMP
System Days	Total days the system has been in service.	SYS. DAYS

## Program Functions

All program functions are password protected. The password for user level is 1234. When the **PROGRAM** Keypad is pressed, the display will prompt the user for the password. After the password is entered (**1234 + ENTER** key), the user can change the Date, Time, Month Test Date, Month Test Time, Yearly Test Date and Yearly Test Time, Load Reduction Fault, Low VAC Alarm, High VAC Alarm, Ambient Temp Alarm and Near Low Battery settings. Time is always in the 24 hour standard. Example 4:00 PM is 16:00.

**Table 7.3 Program Functions**

Parameter	Format	Factory Default
Date	MM/DD/YY (Month, Date, Year)	Current Date
Time	HH/MM (Hours, Minutes)	Eastern Stand Time
Monthly Test Date	DD (Date)	15 <sup>th</sup> of the Month
Monthly Test Time	HH/MM (Hours, Minutes)	5:00
Yearly Test Date	MM (Month)	01
Yearly Test Time	HH/MM (Hours, Minutes)	8:00
Load Reduction	AAAA (AMPS)	0.0A
Low VAC Alarm	VVVV (Volts)	1.0V
High VAC Alarm	VVVV (Volts)	999.9V
Ambient Temp Alarm	DDD (Degrees Centigrade)	70°C
Near Low Battery	VVVV (Volts)	See Table 7.4

**Table 7.4 Near Low Battery Fault Chart**

DC Voltage	Near Low Battery
240VDC	216VDC

## The Day of the Automatic Tests

Table 7.5 shows the purpose of each parameter and its factory setting.

**Table 7.5 Factory Setting for Automatic Test Parameter**

Parameter	Determines...	Factory Default
Monthly Test	The time and the day of the month for the monthly tests.	15 <sup>th</sup> @ 5:00 AM
Yearly Test	The time and the date for the yearly test.	(January) 1 @ 8:00 AM

## The Length of the Automatic Tests

Parameters Monthly Test and Yearly Test determine how long the battery test is. Table 7.6 shows the purpose of each parameter.

**Table 7.6 Factory Setting for Automatic Test Parameters**

Parameter	Purpose	Factory Default for 90 minute systems
Monthly Test	Monthly battery test.	5 Minutes
Yearly Test	Yearly battery test.	90 Minutes

The factory can only reprogram these parameters.

If you would like to change the setting of any of the above parameters, (see table 7.3) follow these steps: (i.e. setting the Time). See Figure 7.3 for Keypad location.

1. Press the **PROGRAM** keypad, enter the user password (**1234**), press the **ENTER** keypad.
2. Press the ► arrow keypad (◀ or ► keypads are used for scrolling through the menu) to the Time parameter (HH/MM) to set the time. **NOTE:** Factory default is Eastern Standard Time and with 24 hour formats. (i.e. 1:00 PM = 1300 hours)
3. Enter correct time for your time zone using the NUMBER keypads, and then press the **PROGRAM** keypad to exit.

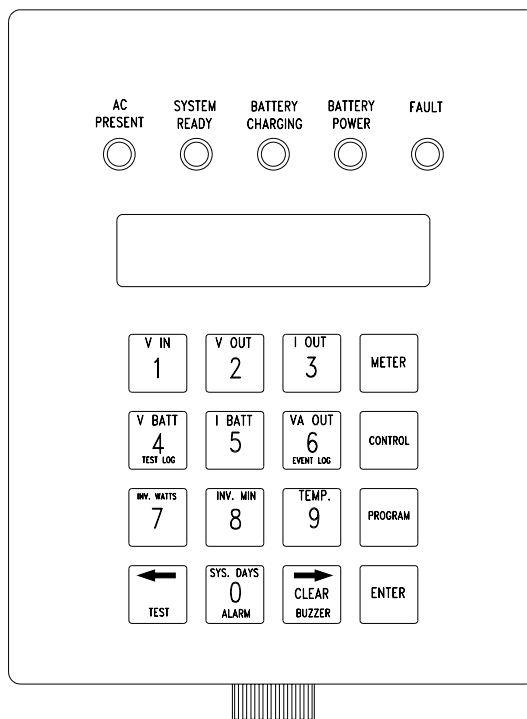

**Figure 7.3 Front Panel Display**

## **Completing the Installation**

Close the doors and lock the cabinet(s). You have finished installing the system. Follow the steps in the Startup and Warranty Validation form to test the installation and startup the system for the first time. After you complete this form, return it to the manufacturer to validate the warranty.

Keep the System Installation Guide and the User's Guide in the folder attached to the inside of the system door.

### **Notes:**

