



INSTALLATION & USER'S GUIDE

1000W - 2800W SINGLE PHASE

Series EM

EMERGENCY LIGHTING CENTRAL INVERTER

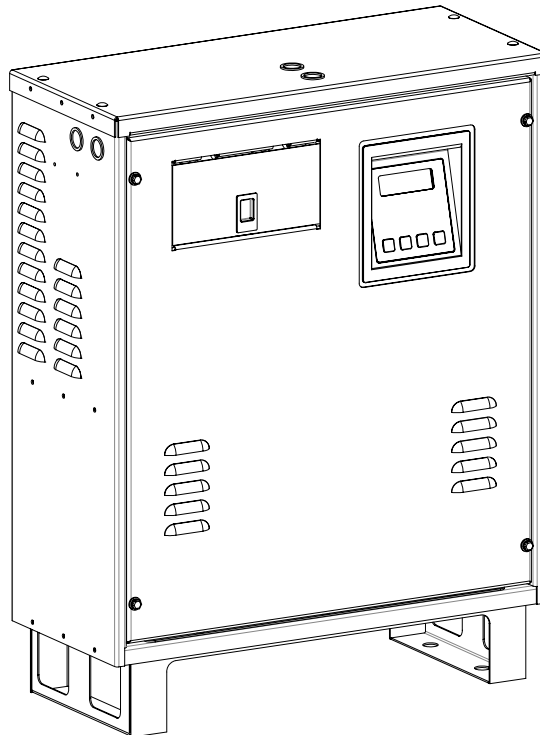

Myers Power Products, Inc.
44 South Commerce Way, Bethlehem, PA 18017
1-800-526-5088 • (610) 868-3500 • Fax: (610) 868-8686
Service: (610) 868-5400
www.myerspwrproducts.com

This unit contains LETHAL VOLTAGES. All repairs and service should be performed by AUTHORIZED SERVICE PERSONNEL ONLY! There are NO USER SERVICEABLE PARTS inside this unit.

IMPORTANT SAFEGUARDS

When using electrical equipment, you should always follow basic safety precautions, including the following:

- 1. READ AND FOLLOW ALL SAFETY INSTRUCTIONS.**
- 2. Do not install the system outdoors.**
- 3. Do not install near gas or electric heaters or in other high-temperature locations.**
- 4. Use caution when servicing batteries. Depending on battery type, batteries contain either acid or alkali and can cause burns to skin and eyes. If battery fluid is spilled on skin or in the eyes, flush with fresh water and contact a physician immediately.**
- 5. Equipment should be mounted in locations where unauthorized personnel will not readily subject it to tampering.**
- 6. The use of accessory equipment not recommended by Manufacturer may cause an unsafe condition and void the warranty.**
- 7. Do not use this equipment for other than its intended use.**
- 8. Qualified service personnel must perform all servicing of this equipment.**

SAVE THESE INSTRUCTIONS

The installation and use of this product must comply with all national, federal, state, municipal, or local codes that apply. If you need help, please call Service. 610-868-5400

CAUTION

**READ ENTIRE MANUAL AND REVIEW ALL DOCUMENTATION BEFORE ATTEMPTING SYSTEM
INSTALLATION!**

FOR SERVICE or INSTALLATION INFORMATION
TELEPHONE: (610) 868-5400 (24 HR. HOTLINE)
FAX: (610) 954-8227

**FOR YOUR PROTECTION....
PLEASE COMPLETE AND RETURN WARRANTY REGISTRATION CARD IMMEDIATELY.**

TABLE OF CONTENTS

	Page(s)
<u>SECTION 1</u>	
Safety Warning	4
Battery Storage	
<u>SECTION 2</u>	
Introduction	5-6
<u>SECTION 3</u>	
Before installing the system	7-12
System Dimensions and Weights	
Location Guidelines	
Storage and operating Environment	
Installation overview	
<u>SECTION 4</u>	
AC input & AC output Installation	13-15
<u>SECTION 5</u>	
Installing batteries and DC wiring	16-21
Safety instructions	
Before installing the batteries	
Installing and connecting the batteries	
Replacing the batteries	
<u>SECTION 6</u>	
Startup and shutdown procedure	22-23
<u>SECTION 7</u>	
Operation	24
<u>SECTION 8</u>	
Keypad/Front Display Panel	25-28
Control panel keypads	
Meter functions	
Control functions	
Program functions	
Automatic tests	
<u>SECTION 9</u>	
Specifications	29
<u>SECTION 10</u>	
Maintenance and service	30-31
Trouble shooting chart	
<u>SECTION 11</u>	
Warranty	32-33

SECTION 1

SAFETY WARNINGS

Read the following precautions before you install this emergency lighting system.

IMPORTANT SAFETY INSTRUCTIONS

SAVE THESE INSTRUCTIONS. This manual contains important instructions that you should follow during installation and maintenance of the system and batteries. Please read all instructions before operating the equipment and save this manual for future reference.

DANGER

This system contains **LETHAL VOLTAGES**. **AUTHORIZED SERVICE PERSONNEL** should perform all repairs and service **ONLY**. There is **NO USER SERVICEABLE PARTS** inside the Emergency lighting power supply.

WARNING

- Do not install the system outdoors.
- Do not install near gas or electric heaters or in other high-temperature locations.
- Use caution when servicing batteries. Battery acid can cause burns to skin and eyes. If acid is spilled on skin or in the eyes, flush with fresh water and contact a physician immediately.
- Equipment should be mounted in locations where it is not readily subjected to tampering by unauthorized personnel.
- The use of accessory equipment not recommended by the manufacturer may cause an unsafe condition.
- Do not use this equipment for other than intended use.
- Only qualified service personnel (such as a licensed electrician) should perform the system and battery installation and initial startup. Risk of electrical shock.

BATTERY STORAGE

This shipment contains rechargeable, maintenance free batteries. They must be stored properly to assure proper operation upon installation. Therefore, please follow the following guidelines when storing batteries:

- Store in clean, dry and cool location. While it is safe to store batteries in environments of -18 to 40 degrees C (0 to 104 degrees F), it is recommended that you do not store at temperatures above 30 degrees C (86 degrees F). The warmer the ambient temperature, the higher the self discharge rate of the battery. This will require more frequent recharge of the individual batteries until they are placed in service.
- Avoid storing in direct sunlight or in front of or near heaters, heat duct or other sources of heat.
- Do not store directly on concrete structures. Always store on wooden pallets or metal shelves near floor level.
- Place the batteries in service within 180 days of receipt. If you cannot place the batteries in service within the 180 days, then the batteries must be recharged every 180 days, (more frequently if stored at elevated temperatures) while in storage. Failure to do so will void the warranty and may cause irreversible damage to the battery.

SECTION 2

INTRODUCTION

Keep this Guide in the folder mounted inside the unit.

This unit is a microprocessor controlled PWM (Pulse Width Modulated) pure sine wave based DC to AC power inverter utilizing IGBT technology. It integrates a fully automatic 3-rate battery charger, a solid-state transfer system, control circuitry, self testing and recording digital meter display, and maintenance free sealed lead calcium type batteries. The system components are carefully matched to make the unit a completely self-contained, fully automatic standby power source for operation on all types of lighting loads. The batteries are sized and tested per UL-924 and Life Safety Code ANSI / NFPA 101, providing emergency power for a minimum of 90 minutes.

If the duration of a power failure is greater than the batteries storage capability, the inverter will automatically shut down when the battery voltage reaches 85% of the nominal DC voltage. This feature protects the battery from being permanently damaged from a deep discharge that could cause cell reversal. This battery protection feature is called "Low Voltage Disconnect" or L.V.D.

When the AC power is restored after a full discharge, the system will be ready for another power failure within 24hrs. If another power failure occurs before the 24-hour recharge time, the run time will be decreased.

The front panel display incorporates a 4 x 20 vacuum fluorescent display and a 4-button keypad. All user interface functions are available from the front panel assembly.

Utilizing a small footprint, this unit is for use with any lighting load including quartz, HID, incandescent, and fluorescent and halogen.

HOW TO USE THIS MANUAL

This manual tells you how to install, start, operate, and communicate with your unit and lets you know how to get more information for special situations.

Please record your unit's part number, serial number, and model number below. You can find these numbers on the label on the backside of the cabinet panel.

Part Number _____

Serial Number _____

Model Number _____

Record Keeping

An on-site permanent log of the inspection, testing, and maintenance of the emergency electrical power supply system shall be maintained in accordance with this manual. The log shall include:

The date on which the inspection, testing, and maintenance exercise was carried out.

The name of the person(s) who performed the inspection, testing, and maintenance.

A note of any unsatisfactory condition observed or discovered, and the steps taken to correct the condition.

Service and Support

We are committed to outstanding customer service. A service technician is available **24** hours a day, **365** days a year. Service is also available **24** hours a day to give you access to technical notes and product information.

NOTE: Please have your unit's Serial and Part numbers available when you call; this number is located on the backside of the cabinet panel.

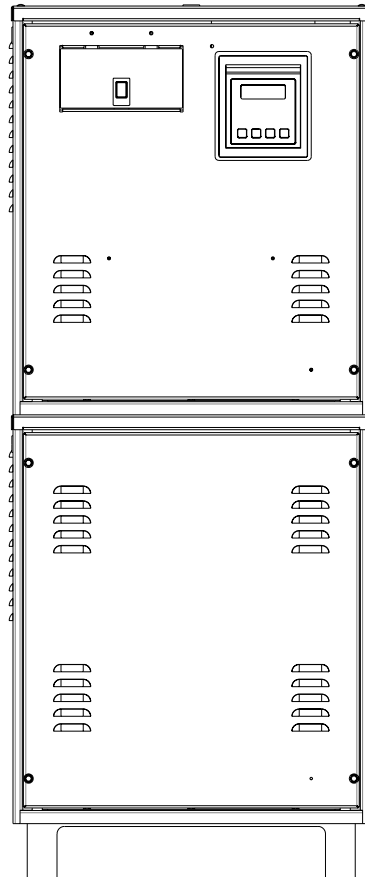

SECTION 3

BEFORE INSTALLING THE SYSTEM

System Dimensions and Weights

Required Clearance

Top – 6" (15.24 cm)
Sides – 6" (15.24 cm)
Front – 36" (91.4 cm)

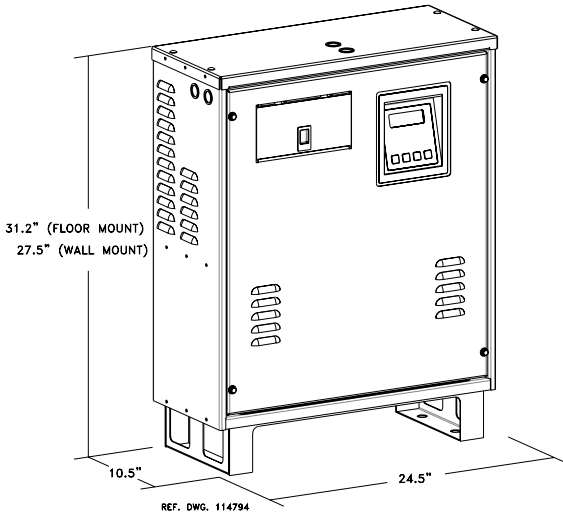

Figure 3.1 1000W System Dimensions

Required Clearance

Top – 6" (15.24 cm)
Sides – 6" (15.24 cm)
Front – 36" (91.4 cm)

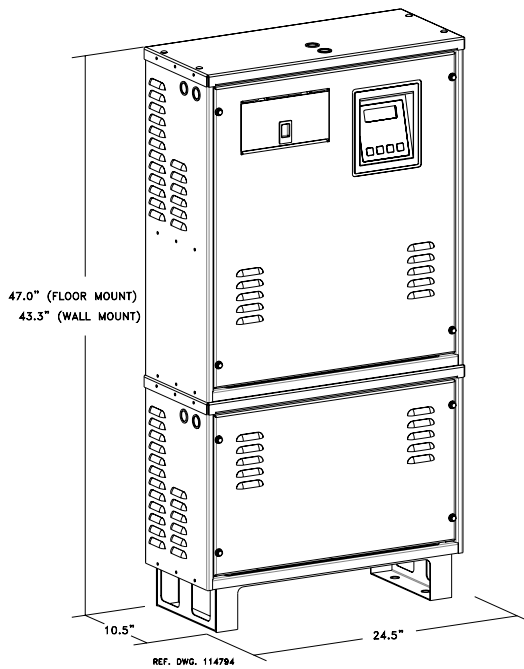

Figure 3.2 1600W-2200W System Dimensions

Required Clearance
 Top – 6" (15.24 cm)
 Sides – 6" (15.24 cm)
 Front – 36" (91.4 cm)

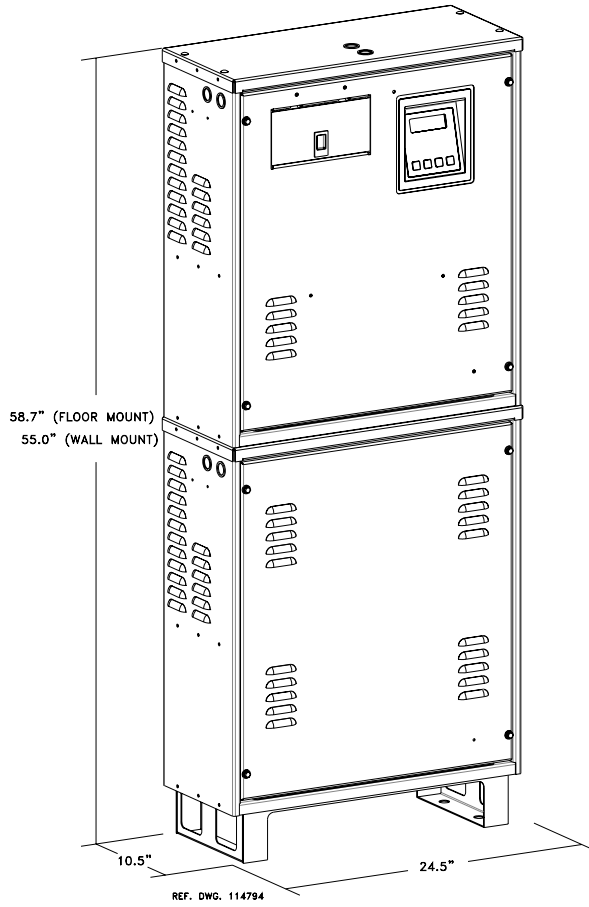
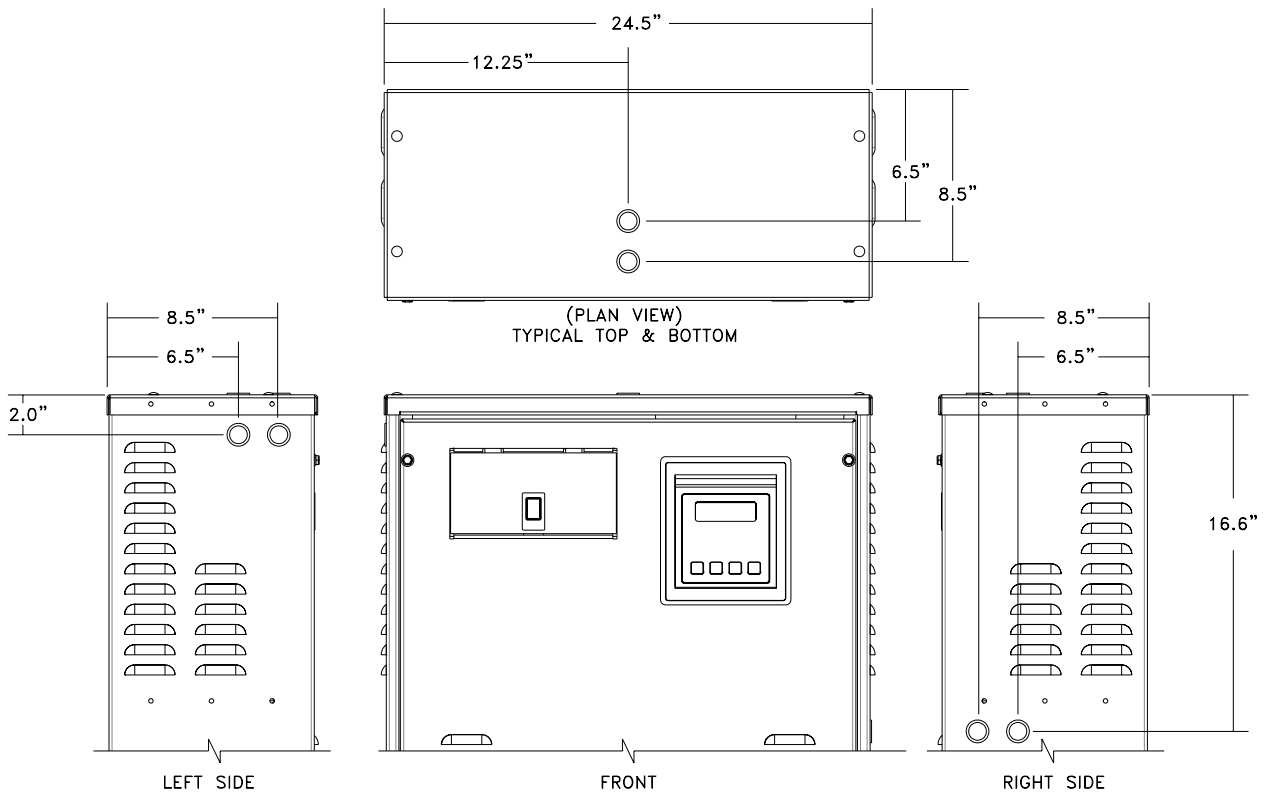

Figure 3.3 2800W System Dimensions

Table 3.1 System weight [in lbs. (kg)]

	1000W	1600W	2200W	2800W
Inverter Cabinet	121 (55)	165 (75)	174 (79)	203 (92)
Batteries	160 (73)	240 (109)	320 (146)	400 (182)
System Total	281 (128)	405 (184)	494 (225)	603 (274)



Knockout Diameter: 7/8" / 1-1/8" (2.2 cm / 2.9 cm)

Figure 3.4 Conduit Knockout Dimensions

Stacking Detail for Systems with a Battery Cabinet

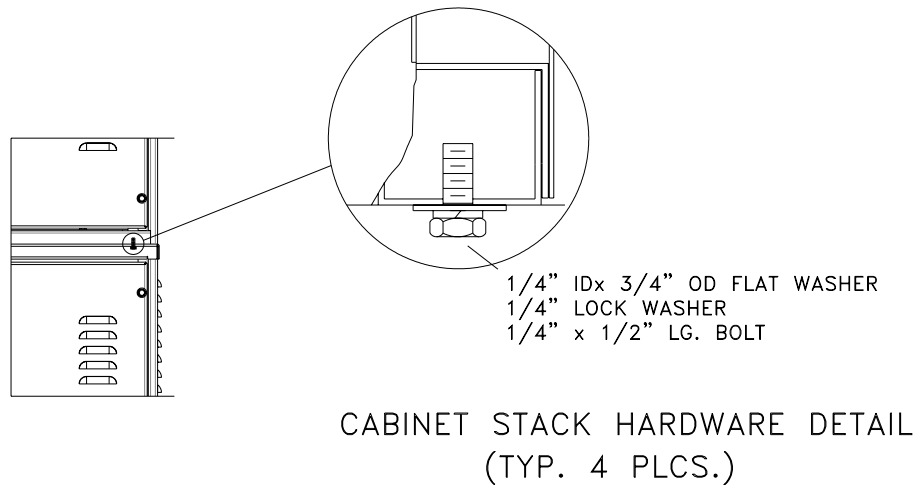

Figure 3.5 Cabinet Stacking Detail (1600W – 2800W)

Location Guidelines

Keep the following guidelines in mind when choosing the location for your system and batteries:

- Verify that the environment meets the requirements in “Storage and Operating Environment” on page 11. The environment can affect the reliability and performance of both the unit and the batteries.
- Choose a permanent location for the unit. Attempting to move the unit after you have installed the batteries can damage the batteries and the cabinet.

CAUTION

Do not move the unit after you install the batteries. If you do, the unit and batteries may be damaged.

CEC (Canadian Electric Code) requires the unit to be located in a service room. If the room is equipped with a sprinkler system, the unit must be provided with sprinkler proof cover.

The system should be connected to the emergency generator, if available.

This equipment is heavy. Refer to Table 3.1 when you choose a site to make sure that the floor can support the weight of the system, the batteries, and any other necessary equipment.

Receiving and Moving the Unit and the Batteries

Systems weigh several hundred pounds, (see Table 3.1; ask your sales representative for additional information). Make sure you are prepared for these weights before you unload or move the unit or the batteries. Do not install any batteries until you have permanently installed the unit and connected all conduit and wiring.

Storage and Operating Environment

Make sure you store and install the system in a clean, cool, dry place with normal ventilation and level floors.

Storage Temperature

Store the batteries (in the system) at -18 to 40°C (0 to 104°F). Batteries have a longer shelf life if they are stored below 25°C (77°F). Keep stored batteries fully charged. Recharge the batteries every 90–180 days. The system without batteries may be stored at -20 to 70°C (-4 to 158°F).

Ventilation

The air around the unit must be clean, dust-free, and free of corrosive chemicals or other contaminants. Do not place the system or batteries in a sealed room or container.

Operating Temperature

System can operate from 20° to 30°C (68° to 86°F) and up to 95% relative humidity. The batteries' service life is longer if the operating temperature stays below 25°C (77°F).

Batteries

The temperature should be near 25°C (77°F) for optimum battery performance. Batteries are less efficient at temperatures below 18°C (65°F), and high temperatures reduce battery life. Typically, at about 35°C (95°F), battery life is half of what it would be at a normal temperature of 25°C (77°F). At about 45°C (113°F), battery life is one-fourth of normal.

Make sure that heaters, sunlight, air conditioners, or outside air vents are not directed toward the batteries. These conditions can make the temperature within battery strings vary, which can cause differences in the batteries' voltages. Eventually, these conditions affect battery performance.

Do not allow tobacco smoking, sparks, or flames in the system location because hydrogen is concentrated under the vent cap of each cell of the battery. Hydrogen is highly explosive, and it is hard to detect because it is colorless, odorless, and lighter than air.

Every type of battery can produce hydrogen gas, even sealed maintenance-free batteries. The gas is vented through the vent caps and into the air, mainly when the unit is charging the batteries. The batteries produce the most hydrogen when maximum voltage is present in fully charged batteries; the batteries do not produce hydrogen during float charging. The amount of current that the charger supplies to the batteries (not the battery ampere-hour) determines how much hydrogen is produced.

High Altitude Operation

The maximum operating ambient temperature drops 1°C per 300m (2°F per 1000 ft) above sea level. Maximum elevation is 3000m (10,000 ft).

Installation Overview

Figure 3.6 shows typical installations.

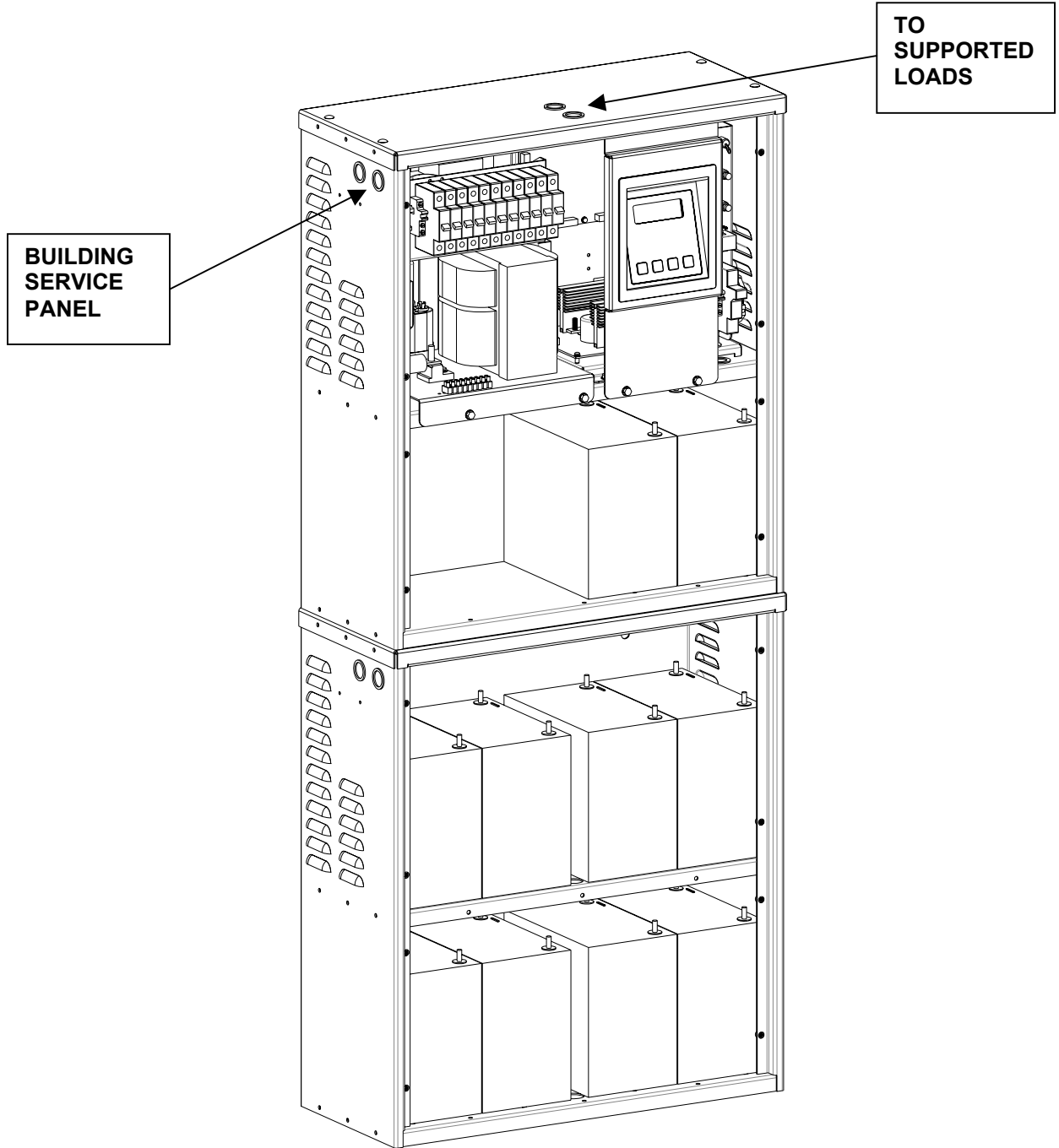

Figure 3.6 Typical Hardwire Installation

SECTION 4

AC INPUT & AC OUTPUT INSTALLATION

WARNING

Only qualified service personnel (such as a licensed electrician) should perform the AC installation. Risk of electrical shock.

Read the following cautions before you continue.

CAUTION

- Unit contains hazardous AC and DC voltages. Because of these voltages, a qualified electrician must install the system, AC line service, and batteries. The electrician must install the AC line service according to local and national codes and must be familiar with batteries and battery installation.
 - Before you install, maintain, or service the unit, always remove or shut off all sources of AC and DC power and shut off the system. You must disconnect AC line input at the service panel and turn off the Installation Switch, open Main AC Input Circuit Breaker and open Battery Circuit Breaker to make sure the unit does not supply output voltage.
 - Whenever AC and/or DC voltage is applied, there is AC voltage inside the unit; this is because the unit can supply power from AC line or from its batteries. To avoid equipment damage or personal injury, always assume that there may be voltage inside the unit.
 - Remove rings, watches, and other jewelry before installing the AC wiring. Always wear protective clothing and eye protection and use insulated tools when working near batteries. Whenever you are servicing an energized unit with the door open, electric shock is possible; follow all local safety codes. TEST BEFORE TOUCHING!
1. Remove the cabinet's front panel(s). Make sure the installation switch is off, the Main AC Input Circuit Breaker is open, and the Battery Fuse(s) is removed inside the unit.
 2. Look at the ID label on the inside of the door. Write down the following information:
Input Voltage: _____
Output Voltage: _____
 3. Now, make sure the input and output voltages are what you need.
 - Does the input voltage available for the system at the AC service panel match the input voltage shown on the unit's ID label?
Service Panel Voltage = _____ Input Voltage ___Yes / ___No
 - Does the output voltage on the ID label match the voltage for your loads (protected equipment) ?
Load Voltage = _____ Output Voltage ___Yes/ ___No
If you answered NO to either of the preceding questions, call SERVICE.
 4. Now, use the information you wrote down in Step 2 to find the correct circuit breaker for the service panel that is for your system.

Table 4.1 Recommended Circuit Breaker for Maximum Input Current

System	Input Voltage (Vac)	Max. Current	Recommended Circuit Breaker
1000W	120V	10.5 amps	15A, 1-Pole
1000W	208V	6.0 amps	10A, 2-Pole
1000W	240V	5.5 amps	10A, 2-Pole
1000W	277V	4.5 amps	10A, 1-Pole
1000W	480V	3.0 amps	10A, 2-Pole
1600W	120V	17.0 amps	25A, 1-Pole
1600W	208V	10.0 amps	15A, 2-Pole
1600W	240V	8.5 amps	15A, 2-Pole
1600W	277V	7.5 amps	10A, 1-Pole
1600W	480V	4.5 amps	10A, 2-Pole
2200W	120V	23.0 amps	30A, 1-Pole
2200W	208V	13.5 amps	20A, 2-Pole
2200W	240V	11.5 amps	15A, 2-Pole
2200W	277V	10.0 amps	15A, 1-Pole
2200W	480V	6.0 amps	10A, 2-Pole
2800W	120V	29.5 amps	40A, 1-Pole
2800W	208V	17.0 amps	25A, 2-Pole
2800W	240V	15.0 amps	20A, 2-Pole
2800W	277V	13.0 amps	20A, 1-Pole
2800W	480V	7.5 amps	10A, 2-Pole

** WARNING: THE EXTERNAL INPUT CIRCUIT BREAKER PROTECTING THE SYSTEM MUST BE A "MOTOR START", DELAYED TRIP TYPE. THIS IS DUE TO MAGNETIC INRUSH CURRENT DRAWN DURING APPLICATION OF AC POWER.

- Write down the circuit breaker value that applies to your system from Table 4.1: _____
- Now, refer to Table 4.2 and use the notes to find the proper gauge wire for the recommended circuit breaker recorded in step 5.

Table 4.2 Recommended Minimum Wire Sizes

Read These Important Notes!	For this Input Circuit Breaker Size...	Use this Size 90°C Copper Wire	
		AWG	mm ²
This table lists the AWG and mm ² wire size for each circuit breaker size. The minimum recommended circuit breaker sizes for each model and voltage application are listed in Table 4.1. The temperature rating of conductor must not be less than 90° C wire. Based on the ampacities given in Tables 310-16 of the National Electrical Code, ANSI/NFPA 70-1993 and NEC article 220. Circuit conductors, must be the same size (ampacity) wires and equipment-grounding conductors must meet Table 250-95 of the National Electrical Code. Code may require a larger wire size than shown in this table because of temperature, number of conductors in the conduit, or long service runs. Follow local code requirements.	10, 15, 20	12	3.31
	25, 30	10	5.26
	35, 40, 45	8	8.36

- The input circuit breaker in the input service panel provides the means for disconnecting AC to the unit. Only authorized persons shall be able to disconnect AC to the unit [see NEC 700-20]. If you are using the input circuit breaker to disconnect AC, you must make sure that only authorized persons have control of the circuit breaker panel to meet the requirements of NEC 700-20.

CAUTION

To prevent electrical shock or damage to your equipment, the Installation Switch, the Battery Circuit Breaker, the AC Input Circuit Breaker and the circuit breaker at the input service panel should be turned off.

8. Install the conduit. You must run the AC input service conductors and AC output conductors through separate conduits. Emergency output conductors and non-emergency output conductors must also be run through separate conduits. Emergency output circuits shall be installed in dedicated conduit systems and not shared with other electrical circuits as described in NEC 700-9(b).

The next step explains where to make the AC connections to the system.

INSTALLING AC INPUT WIRES:

Connect AC utility from the service panel to the system.

For 2-wire input: connect hot wire to the input circuit breaker (CB2) labeled “**LINE**”, connect the common wire to the neutral buss bar labeled “**NEUTRAL**” and connect the ground wire to the ground terminal block labeled “**GROUND**”.

For 3-wire input: connect each hot wire to each of the input circuit breaker (CB2) positions labeled “**LINE**”, connect ground wire to the ground terminal block labeled “**GROUND**”. If there is a common wire required, connect the wire to the neutral buss bar labeled “**NEUTRAL**”.

(See Figure 4.1)

INSTALLING AC OUTPUT WIRES:

Connect load wires to the system’s area labeled “**OUTPUT**”. Connect hot wire to the Main Output Circuit Breaker labeled “**NORM. ON**” or to the **Optional Distribution Circuit Breakers**, the common wire(s) to the Buss Bar labeled “**NEUTRAL**” and the ground wire(s) to the ground terminal block labeled “**GROUND**”. (See Figure 4.1)

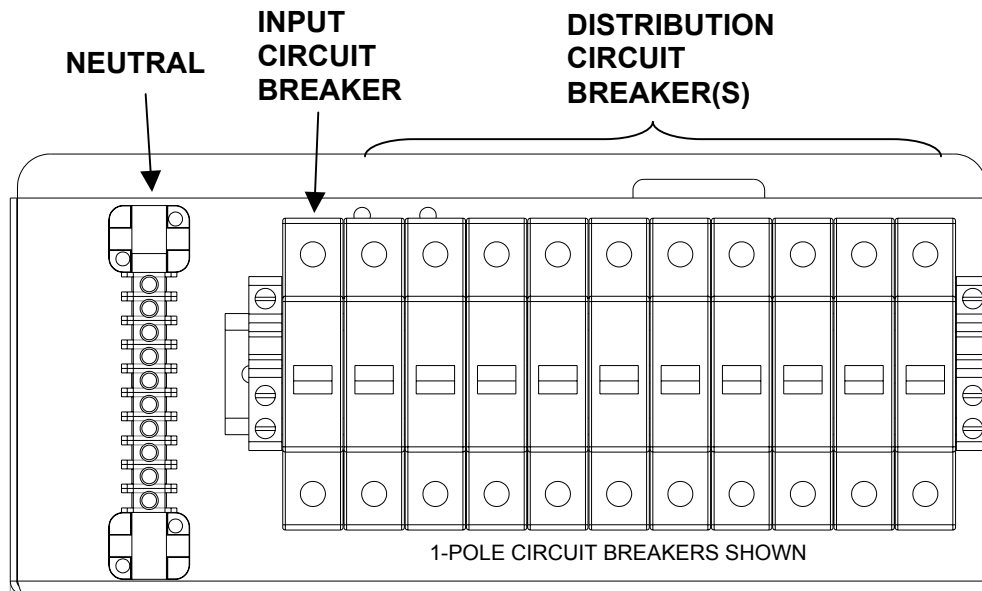

Figure 4.1 AC Input and Output connections

SECTION 5

INSTALLING BATTERIES AND DC WIRING

WARNING

Only qualified service personnel (such as a licensed electrician) should perform the battery and DC wiring installation. Risk of electrical shock.

This section explains how to install system batteries and cables. An electrician who is familiar with battery installations and applicable building and electrical codes should install the batteries.

WARNING

The batteries that will need to be installed in this system could cause you harm or severely damage the electronics if proper precautions are not followed. Batteries connected in series configuration could produce lethal voltages with extreme currents. All batteries should be inspected for damage prior to installation. Never install a battery that is leaking electrolyte. Battery terminals should be cleaned with a wire brush to remove any oxidation. All tools should be insulated. Rubber gloves and safety glasses are recommended. With the Battery Circuit Breaker open and the Battery Fuse removed, make connections to battery negative first, the string's negative and the inverter negative. Then connect each battery positive to the next battery negative. Finally, make connections to battery positive, the string's positive and inverter positive.

Safety Instructions

IMPORTANT SAFETY INSTRUCTIONS

SAVE THESE INSTRUCTIONS

This section contains important instructions that a qualified service person should follow during installation and maintenance of the system and batteries. ONLY a qualified service person should work with the batteries.

CAUTION

Full voltage and current are always present at the battery terminals. The batteries used in this system can produce dangerous voltages, extremely high currents, and a risk of electric shock. They may cause severe injury if the terminals are shorted together. You must be extremely careful to avoid electric shock and burns caused by contacting battery terminals or shorting terminals during battery installation. Do not touch un-insulated battery terminals.

A qualified electrician familiar with battery systems and required precautions must install and service the batteries. Any battery used with this unit shall comply with the applicable requirements for batteries in the standard for emergency lighting and power equipment, UL 924. Cabinets are design to be used with, and batteries must be replaced with, manufacturer battery number or a manufacturer approved equivalent (see the battery wiring diagram that came with the system). If you substitute batteries not supplied by manufacturer, the unit's UL listing is void and the equipment may fail. Installation must conform to national and local codes as well. Keep unauthorized personnel away from batteries.

The electrician must take these precautions:

Wear protective clothing and eyewear. Batteries contain corrosive acids or caustic alkalis and toxic materials and can rupture or leak if mistreated. Remove rings and metal wristwatches or other metal objects and jewelry. Don't carry metal objects in your pockets where the objects can fall onto the batteries or into the cabinet.

Tools must have insulated handles and must be insulated so that they do not short battery terminals. Do not allow a tool to short a battery terminal to another battery terminal or to the cabinet at any time. Do not lay tools or metal parts on top of the batteries, and do not lay them where they could fall onto the batteries or into the cabinet.

Install the batteries as shown on the battery-wiring diagram provided with the system. When connecting cables, never allow a cable to short across a battery's terminals, the string of batteries, or to the cabinet.

Align the cables on the battery terminals so that the cable lug does not contact any part of the cabinet even if the battery is moved. Keep the cable away from any sharp metal edges.

CAUTION

If you are replacing batteries or repairing battery connections, follow the procedure in the section 6 to shut down your system and remove both AC and DC input power.

Before Installing the Batteries

Tools

CAUTION

Always use insulated tools when you work with batteries. Always torque connections to the manufacturer's recommendations.

When you work with system batteries, you need the following tools. The tools must be insulated so they do not short battery terminals to the cabinet. Wear the safety equipment required by local code whenever the door is open and whenever you are working on batteries. Other tools may be necessary for batteries.

- Digital volt-ohm meter
- 7/16" open end wrench
- 3" extension socket
- Ratchet
- Wire brush
- Electrical tape
- Conductive grease
- Brush (to apply grease to terminals)
- Safety equipment required by local codes
- Torque wrench calibrated in inch-pounds or Newton-meters
- 7/16" socket wrench
- Safety glasses with side shields

Battery Voltage (vdc)

Models	1000W	1600W	2200W	2800W
Battery Volts	48v	72v	96v	120v

Battery Cable Sizing

The battery cables or wires used are Number 10-Gauge (5.26 mm²) for all applications:

DC Disconnect

The system has a Battery Circuit Breaker inside the cabinet; this circuit breaker lets you remove DC power from the batteries.

Installing and Connecting the Batteries

Battery Wiring Diagram

You should have received a battery-wiring diagram with your system. This battery-wiring diagram shows how you should install the batteries; make terminal, and circuit breaker connections. Use the diagram as you follow the steps below.

Location

The system batteries belong inside the unit. Before you start installing the batteries, you must install the system in its permanent location. If you have not already done this, see “Location Guidelines” on page 8 to choose a location.

CAUTION

To prevent damage to your equipment, do not move the system after the batteries are installed.

To make sure a location is acceptable for the system, review the requirements in Section 3.

Arranging the Batteries

NOTE As you arrange the batteries, you must be wearing the required safety equipment.

Arrange the batteries in the cabinet only as shown in the battery-wiring diagram. This arrangement is designed to maximize airflow around the batteries. The cabinets are designed so that battery cases should never touch. Air should be free to circulate. Clean the entire surface of all battery terminals with the wire brush before you install the batteries to create good contact points.

Load the batteries into the system. Starting with the bottom shelf, load one shelf at a time.

CAUTION

Never install the batteries in an airtight enclosure.

Battery Cables to the electronics battery terminal block are factory installed.

Torque Wrench

When you make battery terminal connections, use the torque wrench to tighten the battery terminal connections securely. You can find out what torque value to use by finding the battery number on the front of the battery. Then, use Table 5.1 to find the torque value for that battery.

Table 5.1 Battery Torque

Battery Type	Torque
NP55-12B	Torque to 35 in lbs. (3.95 Nm)
LPL12-55-T9	Torque to 35 in lbs. (3.95 Nm)

Follow these steps to connect the cables:

NOTE: For standard 90-minute runtimes, 1000W, 1600W, 2200W and 2800W models have only one battery string.

Using the battery-wiring diagram, determine which batteries belong to each shelf.

1. Connect the cable from the Battery Terminal block **NEG. (-)** to the first battery neg. (-).

Clean the cable connectors with the wire brush before you make the battery connections.

NOTE: As you carry out the following step, use these guidelines:

If you are using conductive grease, apply a thin coating of high-temperature conductive grease on each post and every cable connector before you assemble and torque the connection to slow corrosion.

2. In the battery string, connect the battery cables between the batteries as shown in the battery-wiring diagram (positive terminal to negative terminal). Torque the connections to the value shown for your battery in Table 5.1.
3. Connect the battery cables from one shelf to the next as shown on the battery-wiring diagram. (1600W – 2800W Systems only)

CAUTION

Hazardous voltage is present! System batteries are high current sources. These batteries can produce dangerous voltages, extremely high currents, and a risk of electric shock.

4. Connect the cable from the Battery Terminal Block **POS. (+)** to the last battery pos. (+).
5. Next, using the voltmeter to check the DC voltage between the battery positive (+) and the battery negative (-) on the battery terminal block inside the electronics cabinet. This voltage should be approximately the battery voltage record on the unit ID label. If it is greater than + or – 5% Vdc, review the battery wiring diagram. Correct any wiring errors and recheck the DC voltage; do not go on until your measurement is within + or – 5% Vdc. If the measurement is too high and you cannot find the cause of the problem, call SERVICE.

CAUTION

If you do not verify that voltage and current direction are correct, the equipment may fail.

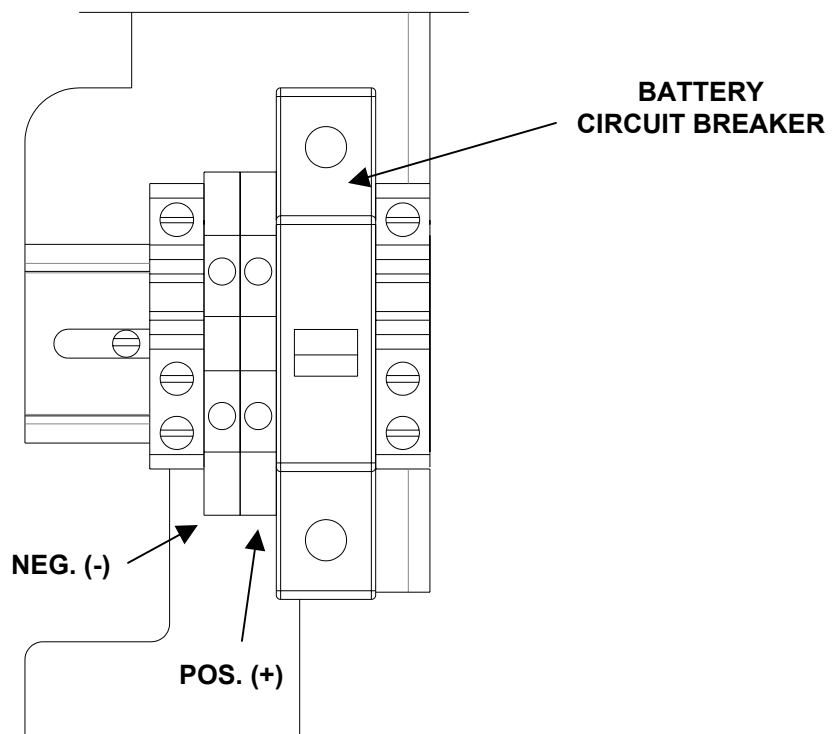

Figure 5.1 Battery Terminal Blocks and Battery Circuit Breaker

Replacing the Batteries

CAUTION

A battery can present a risk of electrical shock and high short circuit current. A qualified electrician familiar with battery systems should service the batteries.

Review all the safety instructions at the beginning of this chapter before you replace any batteries.

Use the Same Quantity and Type of Battery

CAUTION

You must use the same quantity and type of battery. Substituting batteries not supplied by manufacturer voids the UL listing and may cause equipment damage.

To ensure continued superior performance of your system and to maintain proper charger operation, you must replace the batteries in the system with the same number of batteries. These batteries must be the same types as the original batteries. The replacement batteries should have the same voltage and ampere-hour rating as the original batteries.

Handle Used Batteries with Care!

Assume that old batteries are fully charged. Use the same precautions you would use when handling a new battery. Do not short battery terminals or the battery string with a cable or tool when you disconnect the batteries! Batteries contain lead. Please dispose of old batteries properly.

CAUTION

Do not dispose of batteries in a fire because the batteries could explode. Do not open or mutilate batteries. Released electrolyte is harmful to the skin and eyes. It may be toxic.

Dispose of Batteries Properly

CAUTION

Batteries contain lead. Many states and local governments have regulations about used battery disposal. Please dispose of the batteries properly.

SECTION 6

STARTUP AND SHUTDOWN PROCEDURE

STARTUP PROCEDURE

For the initial startup of the system, follow these instructions. Failure to do so will void warranty.

CAUTION: HAZARDOUS VOLTAGES – ONLY QUALIFIED SERVICE PERSONNEL SHOULD PERFORM PROCEDURE.

1. Verify that the installation switch located on the inverter chassis is in the OFF position and the Main AC Input Circuit Breaker and the Battery Circuit Breaker are OFF.
2. Turn on AC input at the building service center.
3. Locate the DC Pre-charge Switch, see figure 6.1; press it for five seconds; then, turn ON the Battery Circuit Breaker. If a large flash occurs, the batteries are not connected properly. Call service immediately.
4. Turn ON the Main AC Input Circuit Breaker. (See figure 4.1)
5. Turn the installation switch to the ON position. System will run on batteries, then transfer to normal mode. The Front Panel will display information.

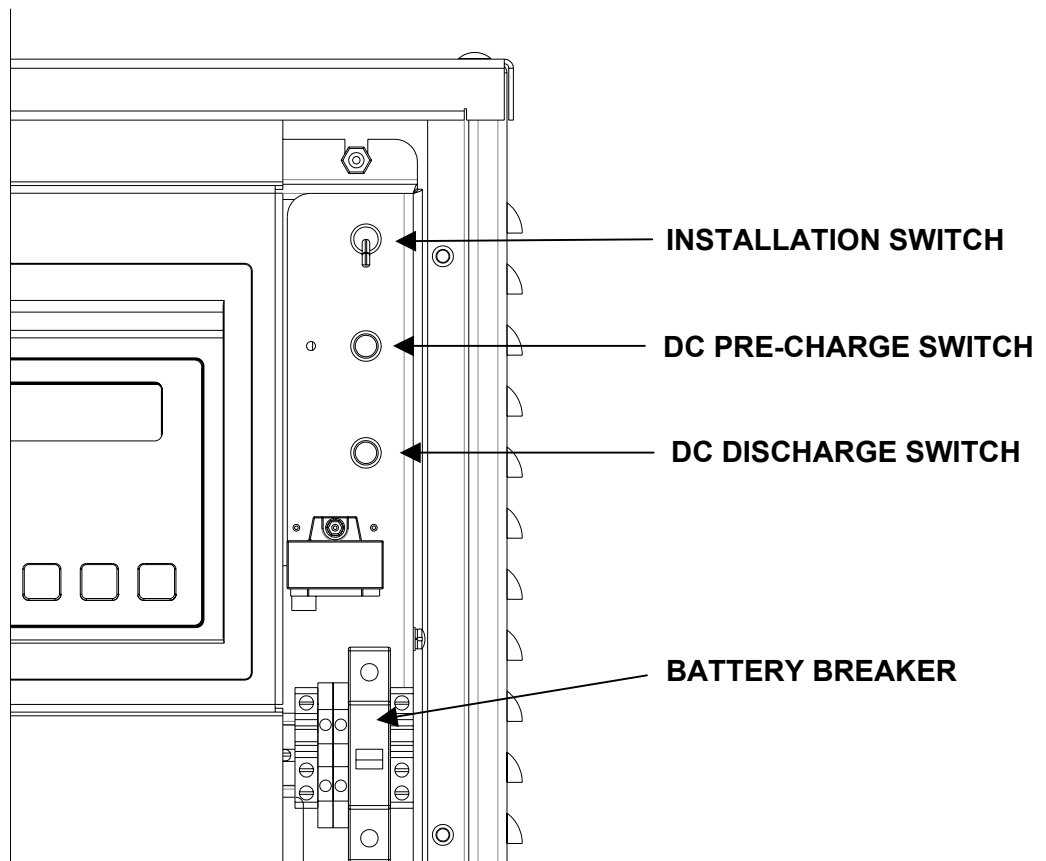

Figure 6.1 DC Pre-charge Switch, DC Discharge Switch & Installation Switch

SHUTDOWN PROCEDURE

1. Turn the installation switch located on the inverter chassis to the OFF position.
2. Interrupt the AC Mains to the system by turning off the circuit breaker at the service center.
3. Turn OFF the Battery Circuit Breaker.
4. Locate the DC Discharge Switch; see figure 6.1; press it for 10 seconds.
5. Turn OFF the Main AC Input Circuit Breaker. (See Figure 4.1)

CAUTION:

HAZARDOUS VOLTAGES STILL EXIST AT THE BATTERY TERMINAL CONNECTIONS AND WITHIN THE SYSTEM. AUTHORIZED SERVICE TECHNICIANS MUST DISCHARGE DC CAPACITORS AND TURN OFF UTILITY POWER BEFORE SERVICING EQUIPMENT.

DO NOT LEAVE THE SYSTEM SHUTDOWN FOR A PROLONGED LENGTH OF TIME. LEAD BASED BATTERIES WILL EXPERIENCE PERMANENT DAMAGE FROM LACK OF CHARGING AFTER A FEW MONTHS.

SECTION 7

OPERATION

The following is a description of the system status located on the panel of the Vacuum Fluorescent Display.

AC Present

When the AC Mains is present, the words “LINE PRESENT” will illuminate. If a power failure was long in duration, or the AC mains was disconnected by some other means (Circuit breaker open) the “LINE PRESENT” would not be illuminated. When the control circuit senses that the line has dropped below an acceptable level (Black Out, Brown Out, or Transient), the inverter will energize for at least one minute. So, if the power failure was a momentary glitch, the “LINE PRESENT” would be illuminated but the inverter would be running.

System Ready

When the system has adequate battery voltage to transfer, the words “SYSTEM READY” will illuminate.

This feature prevents damage from multiple deep discharges of the battery.

Battery Charging

When the AC Mains is connected to the line and the battery is charging under normal conditions, the words “BATTERY CHARGING” will illuminate.

Battery Power

When the inverter is producing output power (battery is being discharged), the words “BATTERY POWER” will be illuminated.

Fault

This is a summary Fault indication. When there is a fault condition present, the word “FAULT” will illuminate. To view which fault is present, use the keypad and vacuum fluorescent display feature.

The panel display will provide the user with a variety of information. It has a full compliment of Meter functions, Control functions and Program functions.

SECTION 8

KEYPAD / FRONT PANEL DISPLAY

The Front Panel Display assembly consists of a 4 x 20 vacuum fluorescent display and a 4-button keypad. The 4 buttons can navigate through all the menus by using the left and right arrow keys, the ENTER and the ESCAPE.

The default menu will scroll between the status screen and the Identification/Date-Time screen. To view the other menu options from the default screen, press the ENTER key, and then press the left or the right arrow key to go to the desired menu.

The Menu's available are Meter, Test Log, Event Log, Alarm Log, User Setup, Factory Setup, Status, System Information, and Test Mode.

Once the desired menu has been reached, press the ENTER key to gain access to this menu. Once into the menu, use the left or right arrow key to scroll to different functions within the menu. Press the ENTER key again to gain access to the desired function. To exit, press the ESCAPE key until the desired level has been reached. (See figure 8.1)

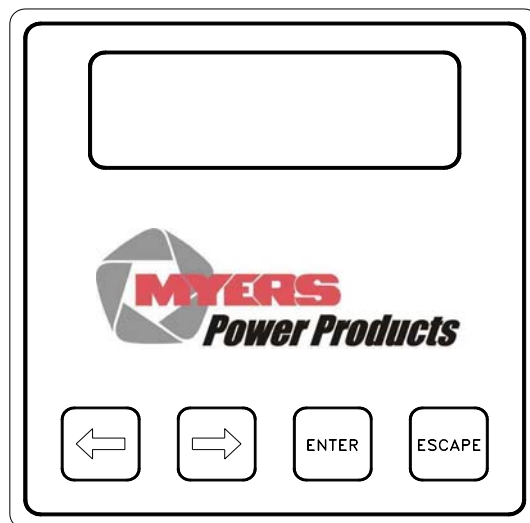

Figure 8.1 Front Panel

Keypads Controls

Table 8.1 Keypad Functions

Key Name	Description
Enter (Blue)	Pressing this key will view menus.
Escape (Black)	Pressing this key will exit out of menus and return to the Identification/Date-Time screen.
[◀] (Red)	This key functions as Left scroll key.
[▶] (Red)	This key functions as Right scroll key.

Meter Functions

To get to the meter functions from the default screen, press the **ENTER** key, scroll to the METER menu using the left or the right arrow key, then press the **ENTER** key again. Use left or the right arrow key to view the meter function desired.

Table 8.2 Meter Functions

Function	Description
Voltage Input	Measures the AC Input Voltage to the Inverter.
Voltage Output	Measures the AC Output Voltage from the Inverter.
Current Output	Measures the AC Output Current from the Inverter.
Battery Voltage	Measures DC Battery Voltage.
Battery Current	Measures the DC Battery Current. When in charge mode, the current will be positive. When in Inverter mode, the current will be negative.
Battery Temperature	Optional feature – measures temperature at the battery.
Internal Temperature	Measures the ambient temperature inside the system.
Inverter Minutes	Indicates the total minutes the system has run on inverter.
System Days	Indicates the total days the system has been on-line.
VA Output	Indicates the AC Volts-Amps of the Inverter output.
Inverter Watts	Indicates the DC Watts (Battery Power) the Inverter is processing.

Test Log

To get to the Test log menu from the default screen, press the **ENTER** key, scroll to the Test log menu using the left or right arrow key, then press the **ENTER** key again. Use the left or right arrow key to view the test desired, and then press the **ENTER** key for more information.

The Test log indicates the Date, Time and Duration of the test. It also indicates if it was a monthly or yearly test, and it records the output voltage, the output current, the ambient temperature, and if there were any alarm conditions.

The numbers of tests that can be captured in the test log are 75. The format is first in is first out so; test number one is the most recent test.

Event Log

To get to the Event log menu from the default screen, press the ENTER key, scroll to the Event log menu using the left or right arrow key, then press the ENTER key again. Use the left or right arrow key to view the event desired, and then press the ENTER key for more information.

The Event log is identical to the test log in parameters it stores. The Event log captures data every time there is a transfer from utility power to battery power. The numbers of events that can be captured in the event log are 75. The format is first in is first out so; event number one is the most recent event.

Alarm Log

To get the Alarm log menu from the default screen, press the **ENTER** key, scroll to the alarm log menu using the left or right arrow key, then press the **ENTER** key again. Use the left or right arrow key to view the alarm desired, and then press the **ENTER** key for more information.

Any alarm that has occurred is captured in the Alarm log. The numbers of alarms that can be captured in the alarm log are 75. The format is first in is first out so; alarm number one is the most recent alarm.

Alarms

To get to the Alarm menu from the default screen, press the **ENTER** key, scroll the Alarm menu using the left or right arrow key, then press the **ENTER** key again.

The alarm menu displays all present alarms. If there are no alarms, the display screen will indicate no alarms.

User Setup

To get to the User Setup menu from the default screen, press the ENTER key, scroll to the User Setup menu using the left or right arrow key, then press the ENTER key again. The display will prompt for a password.

****** The password is left arrow, right arrow, left arrow, and right arrow. ******

Once the password is entered, the user has access to change the following functions:
Date, Time, Month Test, Year Test, Low VAC, High VAC, Near Low Battery, Low Battery, High Temp, Load Reduction Current.

Date

The parameters are Day of Week, Month, Day, and Year.

To change any of the parameters, use the left or right arrow key depending if you want to increase or decrease. Once the parameter is correct, press the ENTER key and the next parameter can be changed.

Time

The parameters are Hour and Minute. The 24-hour standard is used so 2:00 PM would be 14 hours. Use the left or right arrow key to change the parameters and the ENTER key to scroll between parameters.

Month Test, Year Test

The parameters are Date, Time (Hours and Minutes) use the left or right arrow key to change the parameters and the ENTER key to scroll between parameters.

Low VAC, High VAC, Near Low Battery, Low Battery, High Temperature

Parameters are set in Volts AC, Volts DC, and Degrees Centigrade respectively. Use the left or right arrow key to turn on or off this alarm. When the alarm is turned on, a number will appear. To change the number, press the **ENTER** key and then use the left or right arrow key. Once the desired number is reached, press the **ENTER** key and this will return to the top-level menu.

Table 8.3 Near Low Battery Fault Chart

DC Voltage	Near Low Battery
48VDC	43VDC
72VDC	65VDC
96VDC	86VDC
120VDC	108VDC

Load Reduction Current

Parameters are set in Amps AC. Use the same technique as the above alarms for modification. Load Reduction Current is a useful diagnostic tool that will automatically generate a fault when the output current is 10 percent higher or lower than the set-point number.

Status

Indicates the Status of the machine – Line Present, Battery Charging, Ready, Battery Power, and if any faults are present.

System Information

Indicates Model Number, Serial Number and Current Software Revision Level of the system.

Test Mode

To initiate a Test and cause the inverter to run on battery power.

SECTION 9

SPECIFICATIONS

General Specifications

Input	Voltage	120 or 277Vac 1-phase 2-wire +10% -20%. Contact factory for all other voltages.
	Input Power Walk-in	Walk-in limiting inrush current to less than 125%, 10 times for 1 line cycle
	Input Frequency	60Hz, +/- 3%, 50Hz Available upon request
	Synchronizing Slew Rate	1Hz per second nominal
	Protection	Fuse & Circuit Breaker
	Harmonic Distortion	< 10%
	Power Factor	.5 lag/lead
Output	Voltage	120 or 277Vac 1-phase 2-wire. Contact factory for all other voltages.
	Static Voltage	Load current change +/-2%, battery discharge +/-12.5%
	Dynamic Voltage	+/- 2% for +/-25% load step change, +/-3% for a 50% load step change, recovery within 3 cycles
	Harmonic Distortion	< 3% THD for linear load
	Overload	Circuit Breaker protected
	Output Frequency	60Hz +/- .05Hz during emergency mode
	Load Power Factor	.5 lag to .5 lead
	Inverter Overload	115% for 10 minutes
	Protection	Optional Distribution Circuit Breakers
Battery	Type	Valve-regulated sealed lead-calcium.
	Charger	Microprocessor controlled for various battery types and temperature compensating (recharge per UL924 spec)
	Protection	Automatic low-battery disconnect; automatic restart upon utility return.
	Disconnect	Circuit Breaker
	Optional Runtimes	Extended runtimes available. Consult factory for additional information.
Environmental	Altitude	< 10,000 feet (above sea level) without derating
	Operating Temperature	20 to 30 degree Celsius
	Storage Temperature	-20 to 70 degrees Celsius (electronics only)
	Relative Humidity	< 95% (non-condensing)
General	Design	Line interactive PWM inverter type utilizing IGBT technology with 2mS transfer time.
	Generator Input	Compatible with generators.
	Control Panel	Microprocessor controlled 4 x 20-character vacuum fluorescent display with touch pad controls/functions & scrolling system status
	Metering	Input & Output Voltage, Battery Voltage, Battery & Output Current, Output VA, Temperature, Inverter Wattage
	Alarms	High/Low Battery Charger Fault, Near Low Battery, Low Battery, Load Reduction Fault, Output Overload, High/Low AC Input Volts, High Ambient Temperature, Inverter Fault, Output Fault, Optional Circuit Breaker Trip
	Communications	RS-232 port (DB9). Optional E-mail/fax modem.
	Manual Maintenance Bypass	Optional Internal or optional external without internal distribution breakers.
	Alarm Contacts	Optional Summary Form "C" Contacts
	Warranty	1 year standard warranty includes all parts, labor, & travel expenses within 48 contiguous states. Up to 10 years prorated warranty on batteries. Extended warranties, preventative maintenance and customized service plans are available.
	Factory Start-up	Purchase factory start-up & receive 1 additional year of warranty.
5 Year Service Plan	Purchase 5 year service plan & receive free factory start-up.	
Physical	Cabinet	Freestanding NEMA Type 1
	Cooling	Forced Air, during emergency mode.
	Cable Entry	Bottom or Top or Side
	Access	Front

SECTION 10

MAINTENANCE AND SERVICE

The Self-testing feature of the inverter ensures that the system is tested at least once per month for 5 minutes and once per year for 90 minutes. If there are any problems with the self-tests, the fault log shall indicate which faults occurred. Please see the fault descriptions and troubleshooting guide.

A few simple maintenance operations performed periodically will help ensure many years of trouble free operation. Battery terminals should be checked for tightness and corrosion. If severe corrosion is evident, maintenance is required to correct this situation.

Since the unit depends on unrestricted airflow for cooling of power handling components, it is important to keep the air vents free of any obstruction. If the environment tends to be extremely dusty, occasionally blow away any accumulation of dust on components. Please follow the shutdown procedure before cleaning.

CAUTION: Follow the shutdown procedure (See Section 6) before cleaning. An authorized technician only should perform Service!

Table 10.1 Preventive Maintenance Schedule

SERVICE TO PERFORM:	PERFORM SERVICE EVERY:		
	3 MONTHS	6 MONTHS	12 MONTHS
<p>TEST UNIT:</p> <p>NOTE: Perform manual test only when critical load is connected but not required. ----- Output voltage should be present. ----- Confirm operations of Front Panel Indicators.</p>	X		
<p>INSPECT BATTERIES:</p> <p>----- All connections are tight. ----- Connections have no corrosion. (Clean if necessary).</p>		X	
<p>CLEAN UNIT:</p> <p>NOTE: Unit must be shut down during this service. ----- Inspect air vents and clean if necessary. ----- Clean excessive dust from inside cabinet. ----- Clean excessive dust from fan.</p>			X

"X" Indicates when to perform service. Lines below the "X" are for the date of service.

TROUBLE SHOOTING CHART

THE NUMBER IN THE CHART INDICATES ORDER IN WHICH PROBLEMS SHOULD BE CHECKED	SYSTEM PROBLEMS	Inverter will not run during a power failure	System draws excessive AC input current	System noisy, excessive hum during normal run conditions	AC output voltage low during utility power failure	System overheats, smells, smokes, etc.	System noisy, transformer hum during power failure	Inverter jitters or staggers during a power failure	System blows battery fuse (& fuses in battery cabinet if applicable)	Charger not charging properly, low or dead	Charger stays in HI charge	Batteries require continuous addition of water to keep proper level (optional w/ wet cells)	Battery acid leaking in cabinet or around tops of batteries	Battery voltage does not read properly after installation of fresh cells	Battery Voltage low or non-existent
	Installation switch on inverter in off position	1													
	Shorted IGBT module(s)	3	3					1	3						
	No AC input voltage									2					
	Defective inverter	4			2	2	1	3	5						
	Output volt-ampere rating of unit being exceeded	6	1		1	1	2	2	6						
	Ambient temperature too high, vents blocked											3	1		
	Shorted load		2		4		3								
	Reverse battery diodes shorted								2						
	Open battery fuse	2													1
	Battery polarity wrong								1						
	Defective charger	11		1	4					6	1	1	2	4	2
	Battery capacity low	7												3	3
	Low water in battery (Optional w/ wet cells)	10								3					4
	Wrong amount of battery cells in series	9		2		6			4	4	2	2	4	1	5
	Batteries dead, low or defective	8								5	3	4	3	2	
	Transfer module and/or control circuit malfunction	5													
	Transformer not connected for proper voltage		3	3	5					1					

SECTION 11

WARRANTY

RETURN MATERIAL AUTHORIZATION (RMA) POLICY

No return material is accepted without written "Return Material Authorization"(RMA). An RMA number is obtainable by contacting the Field Service Department.

Every effort will be made to correct problems over the phone before a RMA is granted or a service trip made. Cooperation will save both time and expense for customer and manufacturer.

If it is deemed necessary to return material, the RMA number must appear on shipping labels, packing slips, and bills of lading.

OUT OF WARRANTY REPAIR CHARGES AND LABOR

Contact Field service for current parts and labor rates. A minimum rate will be assessed. The manufacturer will not proceed with repairs of an out of warranty unit until authorization in the form of a purchase order is received from the customer. The unit for repair must be returned prepaid with an RMA number on the carton. For travel to the job site, a quote "Not to Exceed" estimate will be given. A purchase order to cover that amount is required before a trip to the job site is made.

LIMITED WARRANTY

The parts and on-site labor for the electronics portion of this equipment are warranted against defects in workmanship and material for a period of one year from time of shipment, but in no case will this warranty be valid if installation of equipment is not accomplished within 180 days from date of shipment. Batteries cannot be disconnected from the unit for long periods (180 days) or they will not be able to charge, creating malfunction of both batteries and/or electronics and thereby voiding the warranty. Systems ordered with "Heavy Lead" batteries over 25 Ah have a one year unconditional battery warranty with an additional prorated warranty contingent upon timely return of warranty registration card and the terms called out in the particular battery warranty sheet. See individual battery warranty policy.

The warranty does not cover damage caused by abuse, improper environmental conditions, shipping damage, improper electronics and/or battery installation, unauthorized modifications, service by unauthorized personnel, transportation of damaged equipment, or acts of war. Damage due to lack of maintenance (where applicable) or damage resulting from installation in areas with other than normal temperatures are not covered. See the battery warranty policy for details, as adverse environmental conditions reduce battery life and void the warranty. Replacement of fuses, pilot lamps, and/or contractor labor is not included in warranty. Damage due to acts of nature, such as, but not limited to, lightning, flooding, explosions and earthquakes, are not covered.

The warranty is limited to the repair and/or replacement of parts and/or units that upon examination at our factory and/or job site are determined to be defective and in our judgment are subject to repair or replacement.

All such repair shall be manufacturer's exclusive remedy. A date code, part number and serial number identify all such units.

TO THE EXTENT ALLOWED BY LAW, MANUFACTURER DISCLAIMS ALL OTHER WARRANTIES, EXPRESS OR IMPLIED, INCLUDING, BUT NOT LIMITED TO, AND LEED WARRANTIES OR MERCHANT ABILITY OR FITNESS FOR A PARTICULAR PURPOSE, AND ANY IMPLIED WARRANTY OF MERCHANT ABILITY OR FITNESS FOR A PARTICULAR PURPOSE ON PRODUCT IS LIMITED IN DURATION TO THE DURATION OF THIS WARRANTY. TO THE EXTENT ALLOWED BY LAW, THE MANUFACTURER SHALL NOT BE LIABLE FOR ANY SPECIAL, INCIDENTAL, OR CONSEQUENTIAL DAMAGES INCLUDING, BUT NOT LIMITED TO, LOSS OF PROFITS, INJURIES TO PROPERTY, LOSS OF USE OF THE PRODUCT OR ANY ASSOCIATED EQUIPMENT.

Special on site extended warranties are also available upon request. The warranty period may be adjusted because of special circumstances, but only by arrangement with the manufacturer at the time of purchase.

All in or out of warranty repaired material or replacement units/parts carry a 90-day new part guarantee. Return of your original repaired component or unit is not guaranteed.

This limited warranty is for the 48 contiguous states.

For international warranty information, call the Field Service Department. See telephone number in front of manual. The standard warranty can be extended and renewed for a nominal fee. Please contact the factory for pricing information.